

Final Compensatory Mitigation and Monitoring Plan

Union Pacific Railroad Great Salt Lake Causeway Culvert Closure and Bridge Construction Project

SPK-2011-00755

Submitted January 7, 2015

Updated May 25, 2016

Prepared for
Union Pacific Railroad
Omaha, NE 68179

Prepared by
HDR Engineering, Inc.
Kidd Waddell
Wally Gwynn

Contents

1.0	Project Description	3
1.1	Purpose of This Plan	3
1.2	Project Background and Project Description	5
2.0	Water and Salt Balance Modeling and Other Studies Completed by UPRR in Support of the Project	8
2.1	Analytical Approach	8
2.2	Summary of the Water and Salt Balance Modeling	9
2.3	Summary of the Bridge Evaluation Report and Related Modeling	10
2.4	Summary of the Resource Evaluation Report	11
3.0	Compensatory Mitigation and Monitoring Plan	18
3.1	Contents of This Plan	18
3.2	Objectives	18
3.3	Site Selection	20
3.3.1	Hydrologic Conditions, Soil Characteristics, and Alignment Considerations	20
3.3.2	Watershed Approach	20
3.3.3	Size and Location of Site Relative to Hydrologic Sources	21
3.3.4	Compatibility with Land Uses and Management Plans	21
3.3.5	Effects of Mitigation Project on Resources	22
3.3.6	Other Relevant Factors	22
3.4	Site Protection Instrument	22
3.5	Baseline Conditions	23
3.5.1	Project Site and Approved Mitigation Site	23
3.5.2	Reference Site	23
3.6	Determination of Compensatory Mitigation	24
3.7	Mitigation Work Plan	24
3.7.1	Final Design Plans	24
3.7.2	Construction Sequencing and Schedule	27
3.8	Maintenance Plan	28
3.9	Performance Standards	28
3.9.1	Causeway Opening Geometry Performance Standards	29
3.9.2	Water Quality (Salinity and Salt Balance) Performance Standard	30
3.10	Monitoring and Reporting	34
3.10.1	Monitoring Parameters	35
3.10.2	Reports and Notifications	40
3.10.3	Salinity and Salt Balance Reporting (Performance Standard 5)	41
3.11	Additional Data Collection	46
3.12	Adaptive Management Plan	48
3.12.1	Causeway Opening Geometry Adaptive Management	49
3.12.2	Salinity and Salt Balance Adaptive Management	50
3.13	Long-Term Management Plan	52
3.13.1	Ownership	52
3.13.2	Sustainability	52
3.13.3	Long-Term Steward	52
3.13.4	Active Long-Term Management Activities	52
3.13.5	Funding Mechanism	53
3.13.6	Justification for Level of Funding	53
3.14	Financial Assurances	54
3.15	Other Information	54
4.0	References	55

Tables

Table 2-1. Summary of Project Effects	13
Table 3-1. Cross-References for Information Required in This Plan	19
Table 3-2. Main Construction Activities	27
Table 3-3. Five-Year Maintenance Activities.....	28
Table 3-4. Information about the UPRR Mitigation Site per the Uniform Performance Standards Worksheet	29
Table 3-5. Causeway Opening Geometry Performance Standards.....	30
Table 3-6. Water Quality (Salinity and Salt Balance) Performance Standard.....	31
Table 3-7. Salinity Performance Standard Range.....	34
Table 3-8. Monitoring Parameters	36
Table 3-9. Monitoring Parameter Methods, Detection Limits, Reporting Limits, and Laboratory Hold Times.....	37
Table 3-10. Monitoring Parameters and Frequency.....	37
Table 3-11. Additional Data Collection Parameters	46
Table 3-12. Additional Data Collection Parameters	47
Table 3-13. Additional Data To Be Collected to Calculate Bidirectional Flow	48

Figures

Figure 1-1. UPRR Project Area.....	6
Figure 3-1. Approved Bridge and Causeway Opening Geometry	25
Figure 3-2. Approved Bridge and Control Berm Plan View	26
Figure 3-3. UPRR/UGS Historic South Arm Salinity Range	33
Figure 3-4. 2012 UPRR/USGS Water and Salt Balance Model South Arm Salinity Range	33
Figure 3-5. UPRR Water-Monitoring Locations In Relation to Other Water-Monitoring Locations.....	39
Figure 3-6. Bridge, Excavated Channel and Earthen Control Berm (Isometric View Looking Southeast).....	51
Figure 3-7. Bridge and Causeway Opening (Looking South)	51

Appendices

Appendix A. U.S. Army Corps of Engineers, Clean Water Act Section 404 Permit (September 7, 2015) as amended September 23, 2015, and February 9, 2017 (this amendment included approval of the Updated Final CMMP)
Appendix B. Utah Division of Water Quality, 401 Water Quality Certification (March 2, 2015)
Appendix C. UDWQ Approval of Updated Final CMMP (June 16, 2017)
Appendix D. Final Bridge and Control Berm Design Plans
Appendix E. Historic and Water and Salt Balance Model Salinity Ranges Analysis
Appendix F. UFFSL Lease
Appendix G. UPRR-UDWQ-USACE MOU and UDWQ-UDFFSL MOU (XXXX, 2017)

1.0 Project Description

1.1 Purpose of This Plan

Union Pacific Railroad (UPRR) operates trains on a rock-filled causeway built by UPRR's predecessor in 1959 across Utah's Great Salt Lake. UPRR sought authorization of permanent closure of the east culvert in the causeway for implementation of a previously authorized compensatory mitigation action to offset the effects of closing the east and west culverts of the causeway by constructing a new bridge with an opening in the causeway. These actions are referred to in this document as the project or proposed project.

The proposed project required an Individual Permit (IP) from the U.S. Army Corps of Engineers (USACE) (USACE 2015; see Appendix A) and a Utah 401 Water Quality Certification from the Utah Division of Water Quality (UDWQ) (UDWQ 2015; see Appendix B). In order to obtain these authorizations and comply with USACE's compensatory mitigation regulations, UPRR prepared and submitted the January 7, 2015, Compensatory Mitigation and Monitoring Plan (CMMP) for USACE and UDWQ approval (UPRR 2015a). The specific conditions of prior authorizations that require UPRR to submit a CMMP are:

- Special Conditions 2 through 6 of the Nationwide Permit (NWP) SPK-2011-00755 authorization issued by USACE in August 2012 (USACE 2012b)
- Special Conditions 2 and 6 of the Nationwide Permit authorization SPK-2011-00755 issued by USACE in December 2013 (USACE 2013b)
- Conditions 4b and 5 of the Utah 401 Water Quality Certification SPK-2011-00755 issued by UDWQ in December 2013 (UDWQ 2013)
- Individual Permit Application submitted by UPRR

Additionally, UPRR and the Utah Division of Forestry, Fires and State Lands entered into a Special Use Lease agreement on September 17, 2015 (UPRR 2015b); this Special Use Lease secures UPRR's access rights over the causeway at this location (Appendix F). As described in the December 13, 2013, USACE and UDWQ public notice for the project, UPRR submitted an Individual Permit Application seeking authorization for permanent closure of the east culvert (which was closed previously under a temporary emergency authorization) and implementation of a previously authorized compensatory mitigation action to mitigate the effects of closing the east and west culverts of the causeway by constructing a new bridge with an opening in the causeway (UPRR 2014a).

UPRR's original compensatory mitigation plan was to construct a 180-foot-long bridge structure with a causeway opening that would replace the aquatic functions provided by the east and west culverts before they were closed (UPRR 2013a). At that time, USACE authorized construction of the bridge subject to UPRR's submission and USACE's and UDWQ's approval of a final compensatory mitigation and monitoring plan.

What is the project?

The project is defined as the permanent closure of the east culvert of UPRR's Great Salt Lake railroad causeway. The project includes constructing a 180-foot-long bridge structure and a control berm that creates a 150-foot-long opening through the causeway to allow water and salt transfer between Gilbert and Gunnison Bays as compensatory mitigation for closing both the east and west culverts.

UDWQ approved the January 2015 CMMP with conditions in issuing its 401 Water Quality Certification on March 2, 2015 (UDWQ 2015). USACE approved the CMMP in issuing its individual permit on September 7, 2015 (USACE 2015). As required by Condition 3H of the March 2, 2015, 401 Water Quality Certification, UPRR updated the January 7, 2015, CMMP¹ to conform it to the Water Quality Certification requirements, including clarifications and modifications required by Conditions 3A-I. As part of its submission, UPRR proposed revisions to CMMP Sections 3.9.2 and 3.10.3 to satisfy and replace the language of Conditions 3A, 3B, 3C1, and 3C.2. The Updated Final CMMP also includes updated Final Bridge and Control Berm Design Plans that conform to the USACE and UDWQ approvals (see Appendix D). UPRR submitted this Updated Final CMMP on May 25, 2016, to UDWQ for approval.

On June 16, 2017, UDWQ approved the Updated Final CMMP, finding that the revisions made in the Updated Final CMMP satisfy the requirements of the March 2, 2015, 401 Water Quality Certification. As part of its approval, UDWQ accepted UPRR's proposed revisions to Sections 3.9.2 and 3.10.3 as satisfying and replacing specific language contained in Certification Conditions 3.A, 3.B, and 3C.1 and 3.C.2. UDWQ approved all other revisions to the CMMP proposed to conform it to the certification conditions, which are incorporated by reference and included as Appendix B. As clarified by UDWQ, all these conditions will be implemented as issued throughout the term of the water quality certification, except that, where such conditions refer to the January 2015 CMMP, compliance with the parallel provisions of this May 25, 2016, Updated Final CMMP will satisfy the requirements of those conditions (see Appendix C).

UPRR also submitted the Updated Final CMMP to USACE for review and approval. On February 9, 2017, USACE approved the Updated CMMP (see Appendix A).

Since the January 2015 CMMP was approved, UPRR, USACE, UDWQ and UDFSL have been working to develop Memoranda of Understanding (MOUs) to provide for long-term management of and access to the mitigation structures and to define the roles of the parties in this regard following the monitoring and reporting period referenced in the regulatory approvals, including circumstances where the State decides to modify the adjustable features of the new causeway opening for lake management purposes. See Water Quality Certification 3.E. and USACE 404 Permit Special Condition 1.I. The MOUs, once finalized and executed, will be appended to the Updated Final CMMP (see Appendix G). Should the State determine to evaluate and then implement a proposal to modify the adjustable features of the new causeway opening for lake management purposes before the end of the regulatory monitoring and reporting period, UPRR will work cooperatively with USACE, UDWQ, UDFSL and other appropriate agencies to facilitate their evaluation and implement their decisions. UPRR anticipates that the evaluation process and resulting decisions in such circumstances would utilize a framework and address factors similar to those addressed in the UPRR-UDWQ-USACE MOU, including reallocation of management and maintenance responsibilities for the modified causeway opening and adjusting UPRR's current regulatory obligations that are bound under the USACE 404 Permit and UDWQ 401 Certification to the construction and operation of the new causeway opening as mitigation of the impacts of closing the two culverts.

¹ Following UDWQ's conditional approval of the January 7, 2015, Proposed CMMP, UPRR revised and resubmitted the CMMP on December 7, 2015. Thereafter, based on additional input from UDWQ, UPRR prepared this Updated Final CMMP, dated May 25, 2016.

1.2 Project Background and Project Description

The project is located in the Great Salt Lake, which is in northwestern Utah. UPRR operates trains on a rock-fill causeway, which separates the lake into areas that are called the North Arm and the South Arm. Water and salt are conveyed back and forth between the lake's North and South Arms through the permeable causeway rock fill and the existing 300-foot-long bridge. Until recently, water and salt were also conveyed back and forth between the lake's North and South Arms through two culverts (the east and west culverts located in the causeway). The east culvert is about 6 miles west of Promontory Point, and the west culvert is about 11 miles west of Promontory Point (Figure 1-1 below). Both culverts are about 15 feet wide by about 20 feet deep. Over time, the culverts settled and became submerged.

When inspections revealed that the culverts were settling and breaking with the risk of collapsing, UPRR met with USACE, UDWQ, and other agencies and then applied in May 2011 for the necessary approvals to close the two culverts. At that time, UPRR also proposed to construct a 180-foot-long bridge and causeway opening to compensate for the loss of water and salt transfer between the North and South Arms that the culverts had historically contributed.

Following the emergency closure of the west culvert, as discussed in more detail below, UPRR reevaluated its proposal and the project's potential adverse effects in response to concerns raised by several state and federal agencies. As the re-evaluation continued, the condition of the culverts continued to deteriorate. USACE authorized the permanent closure of the west culvert in November 2012 on an emergency basis (USACE 2012b). Along with the November 2012 authorization for closing the west culvert, USACE authorized UPRR's compensatory mitigation proposal concept—construction of a 180-foot-long bridge with a 180-foot-long causeway opening—that would replace the arm-to-arm water and salt transfer function that was previously provided by the free-flowing east and west culverts, subject to submission of a compensatory mitigation and monitoring plan.

Figure 1-1. UPRR Project Area

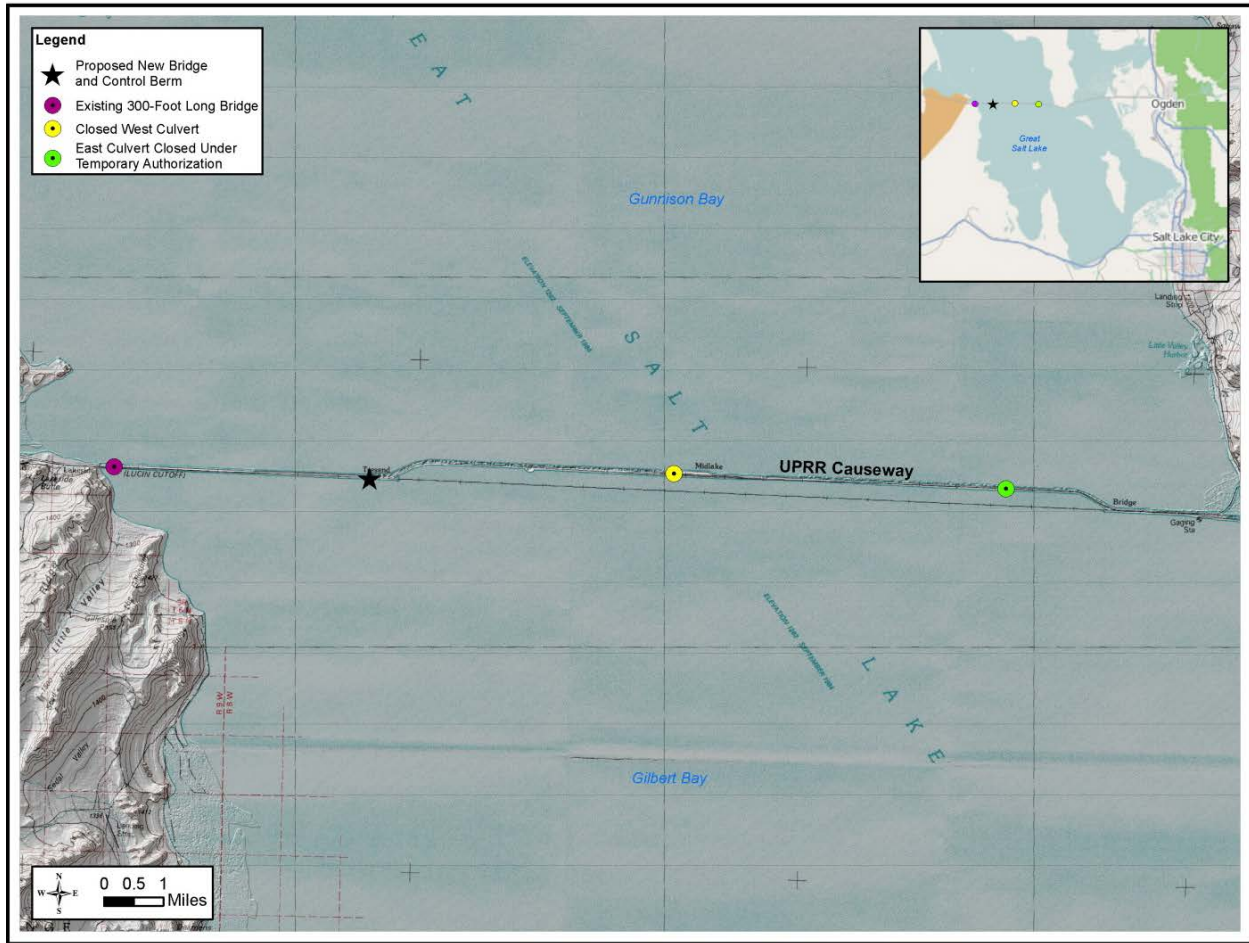

In December 2013, it became necessary for UPRR to close the east culvert under an emergency authorization from USACE when additional inspections identified the imminent risk of the east culvert failing. The 2013 emergency closure of the east culvert also required the approval of UDWQ. USACE authorized temporary closure of the east culvert (USACE 2013b), and UDWQ provided a conditional Utah 401 Water Quality Certification for this temporary closure (UDWQ 2013). USACE’s temporary culvert closure authorization included direction to UPRR to submit an individual permit application to provide a permanent solution.

As reflected in USACE’s direction to UPRR, the objective of UPRR’s compensatory mitigation is to duplicate, as closely as possible, the transfer of water and salt that was occurring through the causeway, between the North and South Arms of the lake, with the free-flowing culverts functioning as documented in November 2012 when it was necessary to close the first culvert (the west culvert).

What is the objective of UPRR’s compensatory mitigation?

The objective of the mitigation is to duplicate, as closely as possible, the aquatic function (water and salt transfer) lost due to the closure of the east and west culverts by constructing a new causeway opening.

The elements of the project and compensatory mitigation proposed by UPRR that were subject to authorization under the federal Clean Water Act consist of the following:

- Authorization for the east culvert to remain closed permanently (this would be an administrative action because the east culvert was previously closed pursuant to the emergency permitting action; it authorized the temporary closure of the failing east culvert pending UPRR's completion of its impacts reevaluation and development of a final compensatory mitigation solution)
- Construction of a temporary shoofly to accommodate rail traffic while the compensatory mitigation (bridge) is installed
- Construction of a 180-foot-long bridge structure, an adjacent control berm (consisting of two side berms and a connecting invert berm on the north side of the causeway), and an excavated channel under the bridge extending to the south to create a 150-foot-long opening through the causeway (referenced collectively herein as the causeway opening or 150-foot-long causeway opening) as compensatory mitigation for the effects of the project (closure of the two culverts) on waters of the U.S, subject to approval of a written compensatory mitigation, monitoring, and adaptive management plan (this CMMP).

What is the shoofly?

The shoofly is a temporary embankment with railroad tracks. The shoofly would be established to reroute train traffic onto a temporary alignment so that construction could occur along the permanent alignment.

What is an invert?

An invert is the bottom elevation of a causeway opening.

The new causeway opening is designed to compensate for the effects on waters of the U.S. associated with the east culvert closure as well as the previously approved closure of the west culvert. The control berm and excavated channel are critical elements of adaptive management.² This CMMP is prepared in support of USACE and UDWQ requirements to ensure that the compensatory mitigation achieves the project's mitigation objective.

² Two elements of the causeway opening, the control berm and excavated channel, were added during final design following issuance of the Bridge Evaluation Report and Resource Evaluation Report in order to facilitate adaptive management. These reports determined that the 150-foot-long opening would meet the project's mitigation objectives; that is, the project would duplicate the water and salt transfer provided by the free-flowing culverts as closely as possible and would have less-than-minimal effects on aquatic resources protected by beneficial uses. Following issuance of the reports, UPRR, in consultation with USACE and UDWQ, determined that constructing the bridge at the original 180-foot proposed length and depth (4,178 feet in elevation), along with a control berm to create a revised length and depth (150 feet long and 4,183 feet bottom elevation) would, in addition to meeting the project's mitigation objective, provide a mechanism for UPRR to make adaptive management adjustments if necessary during the permit monitoring period and for the State to make lake management adjustments following the permit period. With agency concurrence, UPRR added the control berm to the project on the north side of the causeway during preparation of the January CMMP. The excavated channel was extended from the bridge opening to the south of the causeway during final design to ensure that the causeway opening geometry as a whole would meet the specifications for the causeway opening (150 feet long and 4,183 feet bottom elevation) and thereby allow north-to-south flows to pass through the causeway opening into the South Arm as analyzed in the Bridge Evaluation Report and the Resource Evaluation Report.

2.0 Water and Salt Balance Modeling and Other Studies Completed by UPRR in Support of the Project

This section discusses the analytical approach to define project effects on the lake ecosystem and support this CMMP. Summarized are the studies conducted including the water and salt balance modeling report, bridge evaluation report, and resource evaluation report, which also support this CMMP.

2.1 Analytical Approach

During the process of reviewing UPRR's original permitting proposal and proposed compensatory mitigation and monitoring plan in 2012 and 2013, federal and state agencies raised a number of concerns about the potential adverse effects of the project and the sufficiency of the original proposed CMMP, which UPRR submitted in January 2013 pursuant to USACE NWP 14. USACE rejected that CMMP on February 14, 2013, saying:

[T]he Corps is unable to determine [that] the new causeway breach would adequately replace the functions of the culverts and that it would not cause additional adverse effects to the Great Salt Lake and, therefore, we cannot approve the current mitigation plan.

On February 21, 2013, USACE further stated:

Additionally, since the emergency authorization was issued, we have received additional comments from the Utah Division of Water Quality underscoring the unknown effects of the culvert closure and new breach construction. There remain uncertainties about the ability for the new breach to provide the same functions as the culverts and the [proposed new] breach exacerbating the differing salinity concentration [differences] between the North and South Arms of the lake.

Among other things, virtually every agency commenting on UPRR's proposal insisted that UPRR update, calibrate, and use the U.S. Geological Survey's (USGS) 1998 Water and Salt Balance Model of the Great Salt Lake, Utah (referred to in this document as the 1998 USGS Model) to evaluate the effects of carrying out UPRR's proposal on the water and salt balance between the two arms of the lake. UDWQ had been raising concerns about the project since 2011, asserting the need for additional studies and the necessity of using the USGS Water and Salt Balance Model (September 8, 2011, letter to the Utah Public Lands Policy Coordination Office). In a March 2013 letter, UDWQ raised similar objections to the January 2013 CMMP and again called for UPRR to update and recalibrate the 1998 USGS Model (March 1, 2013, letter from Utah Public Lands Policy Coordination Office to USACE).

Based on these concerns, USACE stated in its February 21, 2013, letter:

[T]he Corps suggests UPRR revise its mitigation and monitoring plan to address the Corps' and other agencies' comments and concerns. Further, to help inform the Corps' decision, we strongly encourage UPRR to update the U.S. Geological Survey's Salt Balance Model, working with USGS, to better understand and predict the likely effects of the project on the Great Salt Lake.

In response to these concerns, UPRR undertook a significant re-evaluation of the potential effects of the proposed project in 2013 and met with USACE, UDWQ, and other agencies to coordinate the development of a revised approach. UPRR developed and submitted a comprehensive impacts reevaluation plan dated September 25, 2013 (UPRR 2013b) that reflected this effort. Pursuant to the September 25 plan, UPRR proposed, and has since completed, several studies to support the impacts reevaluation. The water and salt balance modeling requested by the agencies is the central element of this impacts evaluation. The analytical approach used in these studies to assess project impacts and confirm the mitigation proposal was necessarily tied to the model. Similarly, the results of these studies, the feedback that USACE, UDWQ, and other coordinating agencies provided during regular in-person progress meetings and the resulting CMMP are likewise tied to this same USGS model-based analytical approach described in the September 25 plan. The results of the modeling and other impacts evaluation studies are summarized below and are referenced throughout this document.

2.2 Summary of the Water and Salt Balance Modeling

In the first major step of the impacts reevaluation, UPRR conducted a three-step water and salt balance modeling process based on the 1998 USGS Model, as requested by all the agencies. The modeling reevaluated the effects of closing the east and west culverts and constructing the originally proposed 180-foot-long bridge with a 180-foot-long opening in the railroad causeway on the water and salt balance between the North and South Arms of the Great Salt Lake. The steps in the three-step modeling plan were as follows:

- **Modeling step 1:** development of the 1998 UPRR/U.S. Geological Survey (USGS) Model to run under historic hydrologic conditions for the period 1987–1998, plus simulations
- **Modeling step 2:** development of the 2012 UPRR/USGS Model to run under historic hydrologic conditions for the period 1987–2012, plus calibration and simulations
- **Modeling step 3:** development of the 2012 UPRR/USGS Varying Hydrology Model to run under constant wet, mild, and dry conditions for 25 years, plus simulations

The 2012 UPRR/USGS Model simulations (modeling step 2) were based on 26 years of data, and the 2012 UPRR/USGS Varying Hydrology Model (modeling step 3) simulated 25 years of bridge operation. For each step of the modeling plan, the UPRR/USGS model simulated the water surface elevation (WSE), salinity, and salt loads of the North and South Arms of the Great Salt Lake for the following two simulations:

- **Culvert Simulation – Simulated conditions for the east and west culverts before closure of the west culvert in 2012:** The east and west culverts were represented as they existed in November 2012: open and free flowing, and the elevations of the culvert inverts were those from 2012. With these simulations, there are three mechanisms for transferring water and salt through the causeway: the existing 300-foot-long bridge, the two culverts, and the causeway fill. For the purpose of UPRR’s modeling and its entire impacts reevaluation, these causeway conditions are considered the baseline against which the effects of changes associated with the project are compared.
- **Proposed Bridge Simulation – Simulated conditions associated with the bridge proposed as compensatory mitigation for the culvert closures:** The originally proposed 180-foot-long bridge was included as a defined opening in the causeway, and the two culverts were removed (assumed to be filled). With these simulations, there are three mechanisms for transferring water and salt through the causeway: the existing 300-foot-long bridge, the originally proposed 180-foot-long causeway opening, and the causeway fill.

UPRR compared the results of the culvert and proposed bridge simulations for each modeling step (UPRR 2014b). The lake conditions that were compared were WSE; flows through the causeway fill, the existing 300-foot-long bridge, the originally proposed 180-foot-long causeway opening, and the culverts; North and South Arm salt loads; and North and South Arm salinity. For each modeling step, the simulation of the causeway opening at 180 feet long resulted in a denser (more saline) South Arm than with the baseline culvert simulation. The North Arm remained saturated, but with a slightly lower average density in the simulation of the causeway opening at 180 feet long than in the culvert simulation. This is primarily attributable to greater north-to-south flows relative to south-to-north flows for the simulation with the 180-foot-long causeway opening than for the baseline simulation with the free-flowing culverts. Thus, there would be greater net salt transfer from the North Arm to the South Arm with a 180-foot-long causeway opening in place than with the free-flowing culverts in place.

2.3 Summary of the Bridge Evaluation Report and Related Modeling

Based on the results of this three-step modeling effort, UPRR conducted the second element of the September 25, 2013, plan: evaluating adjustments to the geometry of the opening associated with the originally proposed 180-foot-long bridge. As described in the September 25 plan, the purpose of this evaluation was to identify any adjustments to that opening that would more closely duplicate the baseline function and the effects of the east and west culverts than would the original proposal. UPRR studied the effects of various alternative causeway opening geometries on the water and salt balance between the North and South Arms. UPRR compared to the culvert simulation results the results for each alternative causeway opening studied. The results were presented in a Bridge Evaluation Report (UPRR 2014c) submitted to USACE and UDWQ on June 2, 2014.

This evaluation was conducted to determine the appropriate size of the causeway opening to meet the project's compensatory mitigation objective, which is to duplicate, as closely as possible, the aquatic function (water and salt transfer) that was lost due to the closure of the two culverts. The bridge evaluation used the 2012 UPRR/USGS models that had been created for modeling steps 2 and 3. Four alternate causeway opening sizes were incorporated into the model codes for comparison to the culvert simulation.

Based on the analysis of the results of the water and salt balance model simulations described in the Bridge Evaluation Report, UPRR determined that a 150-foot-long causeway opening with an invert elevation of 4,183 feet would most closely match the results of the culverts simulation over the widest range of conditions considered.

Based on the Bridge Evaluation Report, UPRR proposed a change in the causeway opening geometry from a 180-foot-long causeway opening with an invert elevation of 4,178 feet to a 150-foot-long causeway opening with an invert elevation of 4,183 feet. The results of the water and salt balance modeling indicate that the lake conditions in the North and South Arms are most similar for this causeway opening geometry compared to those conditions that would occur under the culvert simulations for the parameters of total causeway flow ratios, salinity ratios, and salt loads. This analysis shows that there would be a slight change in the water and salt transfer from what occurred through the causeway with the culverts in place but that the causeway with the adjusted opening geometry would best replace the aquatic function of the culverts and would provide water and salt transfer through the causeway that would be most similar to that provided by the culverts.

Therefore, as described in the September 25, 2013, plan, UPRR revised the proposed project to include a 150-foot-long causeway opening with an invert elevation of 4,183 feet and analyzed the potential adverse effects of the project as revised (with the 150-foot-long causeway opening) on other Great Salt Lake resources.

2.4 Summary of the Resource Evaluation Report

Based on the results of the modeling and the adjustments to the causeway opening described in the Bridge Evaluation Report, UPRR prepared a Resource Evaluation Report (UPRR 2014d) as part of re-evaluating the effects of closing the east and west culverts and constructing the proposed 180-foot-long bridge structure and 150-foot-long causeway opening on the water and salt balance between the North and South Arms of the Great Salt Lake. The Resource Evaluation Report was the third element of the reevaluation described in the September 25, 2013, letter from UPRR to USACE (UPRR 2013b).

The Resource Evaluation Report provides background information about the project alternatives and discusses the potential effects of UPRR's then-proposed project on the lake's ecological resources compared to baseline conditions. Under the baseline conditions, both culverts are open and free flowing, and the water and salt balance varies from year to year based on a number of factors including lake levels, surface water inflows, density gradients, and causeway characteristics. The culverts are located in the causeway in their positions and elevations as of November 2012, before the west culvert was closed. Under the baseline conditions, the causeway openings included the existing 300-foot-long bridge west of the west culvert and the free-flowing east and west culverts. In addition, water and salt transferred through the permeable rock-fill causeway.

For consistency with the modeling performed in the first element of the impacts reevaluation, the Resource Evaluation Report used the described baseline conditions and the baseline scenario to evaluate the potential effects of the then-proposed project on various resources. These baseline conditions had also been used for developing the culvert simulations that were evaluated as part of the evaluation of project impacts using the water and salt balance model (UPRR 2014b). The baseline scenario recognizes and reflects the natural variability in lake conditions, such as lake level, salinity, and salt load, over time that existed or would have been associated with the culverts if they had remained at their 2012 location and elevation. On this basis, the resource analyses described in the Resource Evaluation Report focused on how the then-proposed project and/or bridge alternatives may affect those resources over time.

In other words, the baseline scenario is not a specific WSE or salinity level in the two arms at any given point but is the WSEs or salinity levels that would exist over time with the culverts open and free flowing with natural and historic variability taken into account. The modeling and resource evaluations assessed potential project effects by first establishing the predicted conditions over time under the baseline scenario and then comparing those conditions with the conditions predicted to occur with the culverts closed and the compensatory mitigation causeway opening in place, taking account the lake's natural and historic variability.

To complete the impacts analysis as described in UPRR's September 25, 2013, impacts reevaluation plan, the Resource Evaluation Report considered whether the slight changes in water and salt balance that would occur with this project (that is, with the 180-foot-long bridge, control berm, and 150-foot-long causeway opening) would have a significant adverse effect on the lake resources described in the report. In order to determine whether the proposed project's potential adverse effects on these resources would be significant, the analyses in the report considered how and whether changes in salinity caused by the

project would cause a significant adverse effect on beneficial uses of the Great Salt Lake as designated by UDWQ.

Each resource evaluated in the report included specific factors for determining whether the proposed project would result in changes to those factors that may cause an effect on a specific resource or resources, outside the historic variability, in a way that would result in a significant adverse effect on the lake's beneficial uses.

What are beneficial uses?

Lakes, rivers, and other water bodies have uses to humans and other life. These uses are called beneficial uses.

During public and agency review of UPRR's original proposal to close the existing culverts and as a result of the recent permanent closure of the west culvert and temporary closure of the east culvert, resource agencies and commenters on UPRR's proposals expressed concerns about potential impacts to Great Salt Lake ecological resources that could result from closing the culverts and constructing the compensatory mitigation (causeway opening). UPRR addressed those concerns in part by evaluating potential adverse effects on those resources in the Resource Evaluation Report. As a result, the resources studied for that report were:

- Water chemistry
- Water quality
- Deep brine layer
- Mercury and methyl mercury
- Biological resources
- Lake circulation

The report concluded with a summary of the potential effects of the project as well as a summary of the project's relationship to the public interest factors evaluated by USACE in its permitting decisions. Table 2-1 below is the summary of project effects from the Resource Evaluation Report (UPRR 2014d).

The resource evaluation identified that, for this project, water quality effects are defined as changes caused by the project that are outside the historic salinity range, as determined by the water and salt balance model results. Lake salinity and salt load changes are used as a surrogate for specific water quality parameters (UDWQ 2014). The Resource Evaluation Report concluded that, with no significant change in salinity, the factors that affect the fate and transport of specific water quality parameters would not be changed, so there would be no significant water quality effect.

UPRR determined, based on the water and salt balance modeling, that the proposed project would cause a slight change in salinity of the South Arm compared to the effect of the baseline conditions (free-flowing culverts). The slight change in salinity is within the historic variability in salinity that has been documented for the lake. Based on a review of the lake's salinity over time and these effects on resources within this range of variability, UPRR determined that the effect of the proposed project would not cause a change in the variable salinity nature of the lake such that it would adversely affect the lake's beneficial uses (recreation and wildlife and their necessary food chain).

Using salinity as a surrogate for water quality as endorsed by UDWQ, the resource evaluation led to a similar conclusion with regard to the effects of the proposed project on water quality. Since the lake's beneficial uses would not be adversely affected as long as the project performs consistent with the analysis, UPRR determined that the proposed project—permanent closure of the east culvert and constructing a new causeway opening associated with the bridge to mitigate the effects of closing the east and west culverts—would not cause a significant change in the salinity variability such that there would be no significant adverse effects on the lake's beneficial uses. Accordingly, with the concurrence of USACE and UDWQ, UPRR revised the project proposal to create a 150-foot-long causeway opening with a 4,183-foot invert elevation and incorporated these changes into the January 2015 CMMP.

Table 2-1. Summary of Project Effects

No-Action Alternative	Approved Alternative	Other Alternatives Considered
Water Chemistry		
Effects on South Arm Salinity (Compared to Baseline Conditions)		
<p>Long-term effects similar to either proposed project or one of the alternatives, depending on the approved compensatory mitigation.</p>	<ul style="list-style-type: none"> • 2012 UPRR/USGS Model: 1.3% average increase • 2012 UPRR/USGS Varying Hydrology Model: 0.3% increase for wet cycle, 0.2% increase for mild cycle, and 1.2% decrease for dry cycle 	<p>Alternative A (180-foot-long causeway opening with invert at 4,178 feet)</p> <ul style="list-style-type: none"> • 2012 UPRR/USGS Model: 2.7% average increase • 2012 UPRR/USGS Varying Hydrology Model: 0.5% increase for wet cycle, 1.0% increase for mild cycle, and 2.6% increase for dry cycle <p>Alternative B (150-foot-long causeway opening with invert at 4,178 feet)</p> <ul style="list-style-type: none"> • 2012 UPRR/USGS Model: 1.9% average increase • 2012 UPRR/USGS Varying Hydrology Model: 0.4% increase for wet cycle, 0.5% increase for mild cycle, and 0.9% increase for dry cycle <p>Alternative D (150-foot-long causeway opening with invert at 4,188 feet)</p> <ul style="list-style-type: none"> • 2012 UPRR/USGS Model: 0.2% average increase • 2012 UPRR/USGS Varying Hydrology Model: 0.2% increase for wet cycle, 0.3% decrease for mild cycle, and 5.3% decrease for dry cycle
Effects on South Arm Salt Load (Compared to Baseline Conditions)		
<p>Long-term effects similar to either proposed project or one of the alternatives, depending on the approved compensatory mitigation.</p>	<ul style="list-style-type: none"> • 2012 UPRR/USGS Model: 0.2-billion-ton (BT) average increase. The total lake salt load is estimated at 4.55 BT. • 2012 UPRR/USGS Varying Hydrology Model: 0.07-BT increase for wet cycle, 0.03-BT increase for mild cycle, and 0.17-BT decrease for dry cycle 	<p>Alternative A (180-foot-long causeway opening with invert at 4,178 feet)</p> <ul style="list-style-type: none"> • 2012 UPRR/USGS Model: 0.35-BT average increase • 2012 UPRR/USGS Varying Hydrology Model: 0.12-BT increase for wet cycle, 0.15-BT increase for mild cycle, and 0.33-BT increase for dry cycle <p>Alternative B (150-foot-long causeway opening with invert at 4,178 feet)</p> <ul style="list-style-type: none"> • 2012 UPRR/USGS Model: 0.24-BT average increase • 2012 UPRR/USGS Varying Hydrology Model: 0.10-BT increase for wet cycle, 0.08-BT increase for mild cycle, and 0.09-BT increase for dry cycle <p>Alternative D (150-foot-long causeway opening with invert at 4,188 feet)</p> <ul style="list-style-type: none"> • 2012 UPRR/USGS Model: 0.01-BT average increase • 2012 UPRR/USGS Varying Hydrology Model: 0.05-BT increase for wet cycle, 0.06-BT decrease for mild cycle, and 0.67-BT decrease for dry cycle

Table 2-1. Summary of Project Effects

No-Action Alternative	Approved Alternative	Other Alternatives Considered
Water Chemistry (continued)		
Construction Effects		
Construction effects similar to either proposed project or one of the alternatives, depending on the approved compensatory mitigation.	Possible short-term water quality effects, due to constructing and removing the temporary shoofly, that are not expected to affect local or lakewide water chemistry	(All alternatives except no action) Possible short-term water quality effects due to constructing and removing the temporary shoofly
Post-construction Short-Term Effects		
Post-construction short-term effects similar to either proposed project or one of the alternatives, depending on the approved compensatory mitigation.	Possible rapid salinity and WSE changes in the project area during the transition period	(All alternatives except no action) Possible rapid salinity and WSE changes in the project area during the transition period
Water Quality		
Long-term, construction, and post-construction short-term effects similar to either proposed project or one of the alternatives, depending on the approved compensatory mitigation.	<p>Long-term Effects Analysis uses salinity as a surrogate for specific water quality parameters; see <i>Water chemistry</i> above</p> <p>Construction Effects Possible short-term water quality effects, due to constructing and removing the temporary shoofly, that are not expected to affect local or lakewide water quality parameters</p> <p>Post-construction Short-Term Effects Possible rapid salinity and WSE changes in the project area during the transition period that are not expected to affect water quality parameters</p>	<p>Long-term Effects See <i>Water chemistry</i> above</p>

Table 2-1. Summary of Project Effects

No-Action Alternative	Approved Alternative	Other Alternatives Considered
Deep Brine Layer		
Effects on Ratio of South-to-North Flow to North-to-South Flow (Compared to Baseline Conditions)		
<p>Long-term effects similar to either proposed project or one of the alternatives, depending on the approved compensatory mitigation.</p>	<ul style="list-style-type: none"> • 2012 UPRR/USGS Model: decrease of 0.33 • 2012 UPRR/USGS Varying Hydrology Model: decrease of 0.10 for wet cycle, decrease of 0.05 for mild cycle, and increase of 0.17 for dry cycle • Mild-cycle ratio would most closely match the baseline conditions under the 2012 UPRR/USGS Varying Hydrology Model 	<p>Alternative A (180-foot-long causeway opening with invert at 4,178 feet)</p> <ul style="list-style-type: none"> • 2012 UPRR/USGS Model: decrease of 0.61 • 2012 UPRR/USGS Varying Hydrology Model: decrease of 0.16 for wet cycle, 0.23 for mild cycle, and 0.25 for dry cycle • Poorest match to the baseline conditions <p>Alternative B (150-foot-long causeway opening with invert at 4,178 feet)</p> <ul style="list-style-type: none"> • 2012 UPRR/USGS Model: decrease of 0.46 • 2012 UPRR/USGS Varying Hydrology Model: decrease of 0.13 for wet cycle, 0.13 for mild cycle, and 0.09 for dry cycle • Dry-cycle ratio would most closely match the baseline conditions under the 2012 UPRR/USGS Varying Hydrology Model <p>Alternative D (150-foot-long causeway opening with invert at 4,188 feet)</p> <ul style="list-style-type: none"> • 2012 UPRR/USGS Model: decrease of 0.05 • 2012 UPRR/USGS Varying Hydrology Model: decrease of 0.07 for wet cycle, increase of 0.07 for mild cycle, and increase of 1.03 for dry cycle • Would most closely match the baseline conditions under the 2012 UPRR/USGS Model and the wet-cycle ratio under the 2012 UPRR/USGS Varying Hydrology Model
Construction Effects		
<p>Construction effects similar to either proposed project or one of the alternatives, depending on the approved compensatory mitigation.</p>	<p>No effect</p>	<p>No effect</p>

Table 2-1. Summary of Project Effects

No-Action Alternative	Approved Alternative	Other Alternatives Considered
Deep Brine Layer (continued)		
Post-construction Short-Term Effects		
Post-construction short-term effects similar to either proposed project or one of the alternatives, depending on the approved compensatory mitigation.	Could increase the Gilbert and Gunnison Bay density gradients for a short time when the bridge is opened; otherwise not expected to affect long-term variability in the density gradient	Same as proposed project for all alternatives
Mercury (Hg) and Methyl Mercury (MeHg)		
Same as proposed project	<p>Long-term Effects</p> <ul style="list-style-type: none"> • Not a source of Hg and not near known sources of Hg • No effects on the factors (source, lake inflows, lake hydrodynamics, and biotic and abiotic processes) thought to contribute to MeHg behavior in the Great Salt Lake <p>Construction Effects</p> <p>No effect</p> <p>Post-construction Short-Term Effects</p> <p>Could increase Gilbert Bay density gradient for a short time when the bridge is opened; otherwise not expected to affect factors that affect MeHg availability as a result</p>	<p>Long-term Effects</p> <p>Same as proposed project for all alternatives</p>

Table 2-1. Summary of Project Effects

No-Action Alternative	Approved Alternative	Other Alternatives Considered
Biological Resources		
Same as proposed project	<p>Long-term Effects</p> <ul style="list-style-type: none"> No effects on salinity variability, so no effects on any brine shrimp life stages No effects on lake levels, so no effects on any brine fly life stages <p>Construction Effects</p> <p>Potential short-term water quality effects could cause short-term local effects on brine shrimp and brine fly habitats</p> <p>Post-construction Short-Term Effects</p> <p>Possible rapid changes in salinity and WSE could temporarily cause local, direct effects on brine shrimp and brine flies but would not adversely affect lakewide conditions that support these elements of the lake’s beneficial uses (necessary food chain)</p>	<p>Long-term Effects</p> <p>Same as proposed project for all alternatives</p>
Lake Circulation		
Same as proposed project	<p>Long-term Effects</p> <p>No effects on factors that influence lake circulation patterns in Gilbert or Gunnison Bays</p> <p>Construction Effects</p> <p>No effects on factors that influence lake circulation patterns</p> <p>Post-construction Short-Term Effects</p> <p>No effects on factors that influence lake circulation patterns</p>	<p>Long-term Effects</p> <p>Same as proposed project for all alternatives</p>

3.0 Compensatory Mitigation and Monitoring Plan

3.1 Contents of This Plan

This plan sets forth the mitigation objectives, performance standards, monitoring and adaptive management elements and all other applicable elements of the USACE regulatory requirements for compensatory mitigation and monitoring plans as well as the requirements of UDWQ for water quality certification under Clean Water Act Section 401. The mitigation method for compensating for these otherwise unavoidable impacts approved by USACE and UDWQ is to construct a 180-foot-long bridge structure and control berm and to create a 150-foot-long causeway opening to be located at railroad milepost 739.78.

UPRR has developed this plan to confirm its mitigation and monitoring responsibilities associated with the entire project. This plan includes monitoring designed to confirm that the approved performance standards (and, therefore, the project's mitigation objectives) are met and describes adaptive management measures that will be undertaken in progressive steps if the causeway opening is not meeting the performance standards.

UPRR has prepared this CMMP to be consistent with USACE's compensatory mitigation regulation [33 Code of Federal Regulations (CFR) 332.4(c)(2)(14)], USACE's guidance and direction to UPRR (USACE 2014), and the requirements of UDWQ for water quality certification. USACE directed that the CMMP should be designed to confirm that the mitigation duplicates the aquatic functions (water and salt transfer) lost due to culvert closure and thereby ensure that the project would have a less-than-minimal effect on the environment (USACE 2013a). UDWQ required that monitoring parameters, frequency of monitoring, and triggers be identified in the mitigation and monitoring plan. In addition, UDWQ required identification of mitigation options that may be implemented based on monitoring results (UDWQ 2013).

This CMMP is based in part on the studies summarized in Section 2.0, Water and Salt Balance Modeling and Other Studies Completed by UPRR in Support of the Project, of this document. Table 3-1 below lists the information provided in this plan, the previous document(s) in which the information was discussed in detail, and the section in this plan where the information is discussed. UPRR determined the project performance standards using the uniform performance standards as a guide and following USACE's *Uniform Performance Standards for Compensatory Mitigation* worksheet (USACE 2012a).

3.2 Objectives

The objective of UPRR's compensatory mitigation is to duplicate, as closely as possible, the aquatic function lost due to the closure of the west culvert and the project and thereby ensure that the project would have no more than a minimal effect on the environment. For purposes of this project, that aquatic function is the transfer of water and salt that was occurring through the causeway between the North and South Arms of the lake with the free-flowing culverts functioning as documented in November 2012 when it was necessary to close the first culvert (the west culvert).

Table 3-1. Cross-References for Information Required in This Plan

Required Information	USACE Compensatory Mitigation Regulation Reference	Previous Document(s)	Section in This Plan
Mitigation plan	33 CFR 332.4(c)	Bridge Evaluation Report and Resource Evaluation Report	3.0
Objectives	33 CFR 332.4(c)(2)	Bridge Evaluation Report and Resource Evaluation Report	3.2
Site selection	33 CFR 332.4(c)(3)	Final Modeling Report, Bridge Evaluation Report, and Resource Evaluation Report	3.3
Site protection instrument	33 CFR 332.4(c)(4)	None	3.4
Baseline conditions	33 CFR 324.4(c)(5)	Bridge Evaluation Report and Resource Evaluation Report	3.5
Determination of compensation	33 CFR 332.4(c)(6)	Final Modeling Report, Bridge Evaluation Report, and Resource Evaluation Report	3.6
Mitigation work plan	33 CFR 332.4(c)(7)	Final Modeling Report and Bridge Evaluation Report	3.7
Maintenance plan	33 CFR 332.4(c)(8)	None	3.8
Performance standards	33 CFR 332.4(c)(9)	Final Modeling Report, Bridge Evaluation Report, and Resource Evaluation Report	3.9
Monitoring requirements	33 CFR 332.4(c)(10)	Final Modeling Report and Bridge Evaluation Report	0
Adaptive management plan	33 CFR 322.4(c)(12)	Final Modeling Report and Bridge Evaluation Report	3.12
Long-term management plan	33 CFR 332.4(c)(11)	None	3.13
Financial assurances	33 CFR 332.4(c)(13)	None	3.14
Other information	33 CFR 332.4(c)(14)	Final Modeling Report, Bridge Evaluation Report, and Resource Evaluation Report	3.15

3.3 Site Selection

As previously approved by USACE, the compensatory mitigation mechanism is placing a new opening in the causeway associated with construction of a new bridge and control berm. The following factors were considered in the mitigation site selection process (that is, the location of the compensatory mitigation causeway opening).

3.3.1 Hydrologic Conditions, Soil Characteristics, and Alignment Considerations

The approved location of the 180-foot-long bridge, control berm, and 150-foot-long causeway opening is in the railroad embankment west of the west culvert. This location is necessary due to railway geometry, soil geotechnical conditions, and hydrologic considerations.

The existing causeway traverses the lake from Promontory Point on the east side of the lake to Lakeside, Utah, on the west side. UPRR reviewed USGS lake bathymetry for the North and South Arms of the lake to determine the deepest part of the lake along the causeway. UPRR selected the location for the new bridge by excluding the geotechnically unstable area of the culverts and avoiding curved segments of railroad track.

The bridge would be located in the causeway at the location that provides the deepest lake water available at a geotechnically stable location and that avoids curved segments of railroad track. When the WSE is at 4,195 feet, the bridge bottom (invert) would be at an elevation of 4,183 feet, and about 12 feet of water would flow through the causeway opening. The lake bottom at the bridge location is at an elevation of about 4,178 feet. This elevation would allow the bridge bottom to be lowered to meet the lake bottom if this were necessary to meet adaptive management or lake management strategies.

UPRR considered placing the bridge, control berm, and causeway opening farther to the west, toward Lakeside. However, as the causeway approaches Lakeside, the lake bottom rises, making the lake shallower. Bridge locations to the west were not considered due to the shallow lake bottom in that area, which would result in a lower water depth through the bridge and less water and salt transfer through the causeway.

The bridge could not feasibly be constructed in the same location as the culverts due to the unstable geotechnical soil conditions found in this section of the causeway, which includes the east and west culvert locations. These unstable soil conditions led to the failure of the culverts, so this area is an unacceptable location for the new bridge structure and causeway opening.

3.3.2 Watershed Approach

The USACE watershed approach for compensatory mitigation sites evaluates factors that applicants should consider when selecting the type and location of the compensatory mitigation. These factors include current trends in habitat loss or conversion, the cumulative effects of past development activities, and existing environmental concerns, such as water quality, within the same watershed. USACE identifies the extent of the watershed to be the same 8-digit Hydrologic Unit Code (HUC) and sub-watershed where the project would be located.

The HUC is a unique code assigned to watersheds by the U.S. Geological Survey (USGS). The Great Basin Region is region 16, the Great Salt Lake Subregion is subregion 1602, the Great Salt Lake

Accounting Unit is accounting unit 160203, and the Great Salt Lake is cataloging unit 1602310 (USGS, no date). The lake's watershed is further subdivided, but, for this project, the 8-digit HUC is sufficient because the project and its mitigation site would be located within the same cataloging unit (the open water of the lake). Consistent with USACE's watershed approach, the mitigation site is located within the same 8-digit HUC (16020310) and sub-watershed as the area of potential impacts from the project.

The mitigation site location in the causeway provides water and salt transfer capability, hydrologic connection, and habitat connectivity between the North and South Arms similar to that provided by the culverts when they were functioning in 2012 before the west culvert was closed.

The selected mitigation site location would allow transfer of water and salt through the causeway that would be most similar to what occurred with the free-flowing culverts (for more information, see Section 2.2, Summary of the Water and Salt Balance Modeling). The location of the mitigation site also would provide a hydrologic connection between the two arms of the lake that would allow water to flow from the North Arm to the South Arm and vice versa. The results of the water and balance modeling indicated that lake conditions in the North and South Arms with the proposed bridge geometry would be the most similar to the lake conditions under the culvert simulations for the parameters of total causeway flow ratios, salinity ratios, and salt loads.

This analysis shows that there would be a slight change in the lake salinity and salt loads and that the approved bridge geometry would best replace the aquatic function of the culverts and would provide water and salt transfer through the causeway similar to what was provided by the culverts.

The approved mitigation location would provide the same open-water habitat connectivity as the culverts, since both locations allow the open water of the North Arm (Gunnison Bay) and the South Arm (which includes Gilbert Bay and other bays) to be exchanged through openings in the causeway and the causeway's permeable rock fill. The water quality of the open waters of Gunnison and Gilbert Bays are protected by the State of Utah to meet the beneficial uses of recreation and wildlife.

3.3.3 Size and Location of Site Relative to Hydrologic Sources

The mitigation site in the railroad causeway is of adequate size and nature to support constructing, operating, and maintaining a bridge structure, control berm, and causeway opening. There is one other bridge in the causeway west of the approved site location, and this existing 300-foot-long bridge allows similar aquatic function as the approved mitigation bridge. The existing bridge, which was constructed in 1984, is located closer to Lakeside and has a bridge bottom of about 4,192 feet in elevation.

The approved mitigation site is located between the North and South Arms of the lake. The project would not use water from the lake but would allow lake water to transfer between the two arms.

3.3.4 Compatibility with Land Uses and Management Plans

The location of the mitigation site would be compatible with current transportation land use in the project area. The site would be located in the Great Salt Lake, which is managed consistent with the direction in the *Great Salt Lake Comprehensive Management Plan* (UDFFSL 2013). The Utah Division of Forestry, Fire and State Lands (UDFFSL) is responsible for managing state sovereign lands, including the Great Salt Lake. UPRR and UDFFSL entered into a Special Use Lease agreement on September 17, 2015; this Special Use Lease secures UPRR's access rights over the causeway at this location (UPRR 2015b; Appendix F). See Water Quality Certification Condition 7.

3.3.5 Effects of Mitigation Project on Resources

During public and agency reviews of UPRR's original proposal to close the existing culverts, and as a result of the recent permanent closure of the west culvert and temporary closure of the east culvert, resource agencies and commenters on UPRR's proposals expressed concerns that closure of the culverts and implementation of the mitigation (building a new bridge with a causeway opening) as then proposed could adversely affect the resources in the lake in addition to adversely affecting the water and salt balance. Therefore, as summarized in Section 2.4, Summary of the Resource Evaluation Report, UPRR conducted resource reviews based on the comments it received and submitted evaluations of the following resources in the Resource Evaluation Report to the agencies (UPRR 2014d):

- Water chemistry
- Water quality
- Deep brine layer
- Mercury and methyl mercury
- Biological resources
- Lake circulation

UPRR studied each resource to determine the following information:

- **Affected environment:** the current environment (existing conditions) pertaining to the resource and the current scientific understanding of the resource
- **Environmental consequences:** the proposed project's potential effects on the resource with various alternative bridges and with the no-action alternative, and any short-term post-construction effects

The results of the resource evaluations are summarized in Table 2-1, Summary of Project Effects, on page 13.

3.3.6 Other Relevant Factors

UPRR reviewed other relevant factors including public interest factors as identified in 33 CFR 340.4 and summarized the applicability of each factor to the proposed project. The factors included in the review are conservation, economics, aesthetics, general environmental concerns, wetlands, historic properties, fish and wildlife values, flood hazards, floodplain values, land use, navigation, shore erosion and accretion, recreation, water supply and conservation, water quality, energy needs, safety, food and fiber production, mineral needs, considerations of property ownership and, in general, the needs and welfare of the people.

The review of the public interest factors is provided in Table 9-2, Summary of the Project's Relationship to the USACE Public Interest Review Factors, of the Resource Evaluation Report (UPRR 2014d).

3.4 Site Protection Instrument

UPRR has obtained a Special Use Lease confirming its access rights to operate and maintain rail facilities for the alignment of the existing causeway where the bridge structure and causeway opening would be located (UPRR 2015b; see Appendix F). Because the mitigation (bridge structure and causeway opening) would be part of the railroad causeway and infrastructure, it would be protected and maintained in the normal course of railroad operation and maintenance in accordance with Section 3.13, Long-Term Management Plan.

3.5 Baseline Conditions

3.5.1 Project Site and Approved Mitigation Site

The approved project site is located along the UPRR Great Salt Lake causeway as shown on Figure 1-1, UPRR Project Area, on page 6. The existing aquatic resources at the project site are classified as open saline waters of Gilbert and Gunnison Bays of the Great Salt Lake by the UDWQ Standards of Quality for Waters of the U.S. (Utah Administrative Code R317-2-6, Use Designations, as in effect March 1, 2014). The baseline conditions at the project site are the same as those of the approved mitigation site because both the project site and the mitigation site are located within the lake and are near each other.

The physical conditions at the project site (culvert locations) are similar to those of the approved mitigation site (bridge location) because both the project site and the mitigation site are located on the causeway, are within the lake, and are near each other. However, for purpose of the impacts reevaluation associated with the project and the establishment of performance standards, the baseline conditions have been analyzed and described as discussed below and in Section 2.0, Water and Salt Balance Modeling and Other Studies Completed by UPRR in Support of the Project.

Because the culverts prior to closure contributed to but were not the only source of water and salt transfer between the North and South Arms, baseline conditions were evaluated in the context of the overall water and salt transfer through the causeway that occurred with the culverts in place. UPRR conducted water and salt balance modeling of the lake to determine the baseline conditions. The term *baseline conditions* refers to the ecological and physical state of the project area before either culvert was closed and before the compensatory mitigation project is implemented.

Under the baseline conditions, both culverts are open and free flowing, and the water and salt balance between the two arms of the lake varies from year to year based on a number of factors including lake levels, surface water inflows, density gradients, and causeway characteristics. The culverts are located in the causeway in their positions as of November 2012, before the west culvert was closed. The causeway openings include the opening through the existing 300-foot-long bridge west of the culverts and the free-flowing east and west culverts. Water also flows through the permeable rock-fill causeway.

UPRR used these baseline conditions to evaluate the effects of the proposed project on various resources because these conditions were present during recent studies focused on the lake and were used for developing the culvert simulations that were evaluated as part of the evaluation of impacts using the water and salt balance model. UPRR presented the findings pertaining to the baseline conditions and potential impacts of the proposed project in the Modeling Report, Bridge Evaluation Report, and Resource Evaluation Report (UPRR 2014b, 2014c, 2014d).

Except for the position of the culverts before closure, the baseline scenario is not tied to a specific date because lake conditions and its resources have varied over time. The baseline scenario represents the natural variability in lake conditions such as lake level, salinity, and salt load over time so that the resource analyses described in the Resource Evaluation Report could assess how potential project and/or bridge alternatives may affect those resources over and above the natural variability over time. These are the conditions that would be associated with the culverts when they were open and free flowing in November 2012, before it became necessary to close the first culvert (the west culvert).

3.5.2 Reference Site

No reference site is identified for this mitigation plan.

3.6 Determination of Compensatory Mitigation

As summarized in Section 2.0, Water and Salt Balance Modeling and Other Studies Completed by UPRR in Support of the Project, UPRR prepared and submitted (on September 25, 2013) an impacts re-evaluation plan for conducting water and salt balance modeling and determining the effects of the proposed project on the lake's ecological resources. The final modeling and the bridge evaluation studies were conducted to assess whether the proposed mitigation would provide the required compensation for project effects on aquatic resources (UPRR 2014b, 2014c). In conducting these studies, UPRR determined that a 150-foot-long causeway opening with an invert elevation of 4,183 feet would best match the aquatic functions (water and salt transfer) of the east and west culverts when they were free-flowing and in their 2012 positions and thereby result in less-than-minimal effects.

Given the unique nature of this project and its potential adverse effects on aquatic resources, the compensatory mitigation solution is providing a new opening in the causeway to replace the aquatic functions lost as a result of the culvert closures. There are no credits available that would satisfy the mitigation objectives for this project. Therefore, UPRR does not intend to obtain credits from an approved mitigation bank or in-lieu fee program for this project.

3.7 Mitigation Work Plan

This section includes conceptual and final design plans for the approved causeway opening, construction and removal of the temporary shoofly, and permanent closure of the east culvert. The sequence of construction activity and the construction schedule are also discussed. The permanent closure of the east culvert is an administrative approval, so no construction activities are required to complete the permanent closure of the east culvert.

As reflected in the modeling and resource evaluation reports (UPRR 2014b, 2014c, 2014d), UPRR determined that a 150-foot-long causeway opening would most likely match the contribution to water and salt transfer through the causeway that was previously provided by the culverts and have less-than-minimal effects on the environment. However, to facilitate adaptive management and future lake management activities, UPRR proposes to construct a 180-foot-long bridge structure with a control berm to create a 150-foot-long causeway opening with an invert at 4,183 feet. The control berm may be adjusted as described below to enlarge or reduce the causeway opening if such an action is triggered by the monitoring and adaptive management to meet the performance standard as set forth in this plan. The following sections describe the bridge structure, the control berm that would create the causeway opening, and adaptive management.

3.7.1 Final Design Plans

UPRR submitted conceptual plans in the January 2015 CMMP and since then has prepared and submitted final design plans for the approved project, including constructing and removing the temporary shoofly, constructing the bridge structure, and constructing the control berm and excavated channel. Appendix D includes bridge plans that illustrate the 180-foot-long bridge structure, including bridge span, side slopes, bridge invert, the control berm, and shoofly geometry. Figure 3-1 below illustrates the key geometric features of the approved bridge structure and causeway opening geometry.

Figure 3-1. Approved Bridge and Causeway Opening Geometry

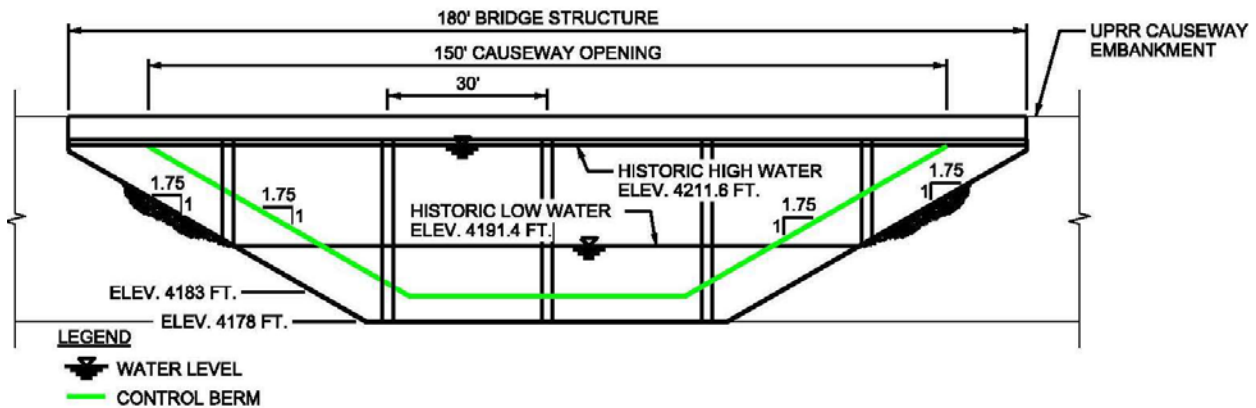

The main elements of the mitigation structure are the 180-foot-long bridge structure and the earthen control berm. The control berm would be located on the north side of the causeway to create an effective 150-foot-long opening through the causeway. The control berm would include a raised invert that elevates the natural lake bed from 4,178 feet to 4,183 feet. This elevated invert caused by the control berm would also restrict north-to-south flows through the causeway.

The control berm geometry was determined by the water and salt balance model to effectively narrow the 180-foot-long bridge structure to a 150-foot-long opening, thereby providing the appropriate ratio of north-to-south flows compared to south-to-north flows as described in the Bridge Evaluation Report (UPRR 2014c). The model simulations indicated that the causeway with the 150-foot-long opening would most closely duplicate the contribution of salt transfer by the causeway with the culverts before they were closed. UPRR determined that the construction of the 180-foot-long bridge with the control berm to adjust the opening to 150 feet long would be beneficial for implementing adaptive management measures in the future, if required. The control berm would be placed just north of the causeway and may be accessed from the causeway access road. With this configuration, work may be conducted on the control berm while not directly interfering with the causeway railroad access road, railroad operations, or bridge structure.

Figure 3-2 below presents a conceptual view of the causeway with the approved bridge structure, railroad causeway access road, and control berm.

Figure 3-2. Approved Bridge and Control Berm Plan View

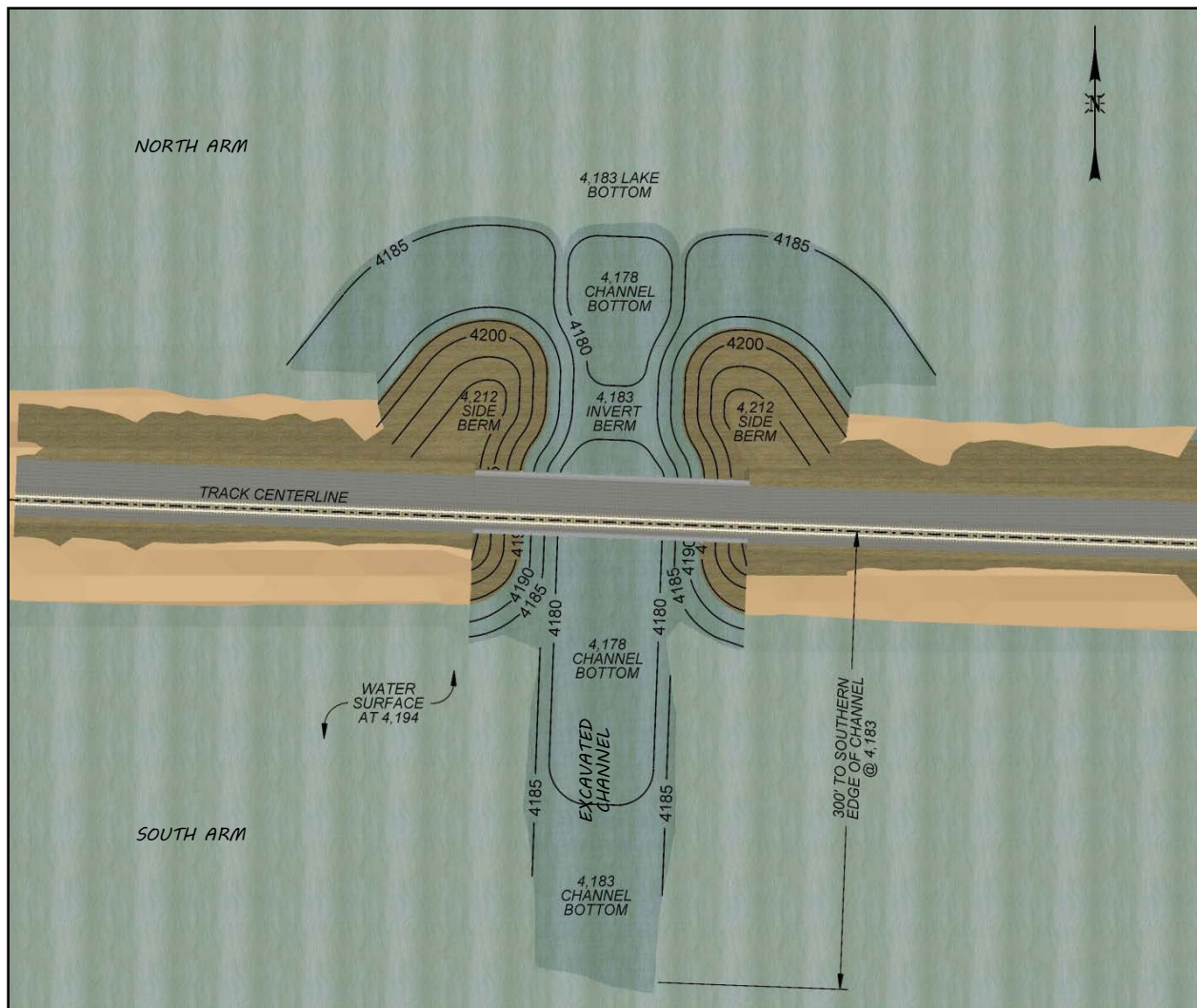

Following approval of the January 2015 CMMP, UPRR developed detailed engineering drawings, specifications, and construction documents for the approved bridge and control berm. UPRR designed the bridge structure in accordance with the American Railway Engineering and Maintenance-of-Way Association's recommended practices. The construction documents will include details on the best management practices that will be implemented during construction activities. The detailed construction documents would be implemented by a contractor under UPRR's direction and approval.

During final design, the excavated channel was extended to the south to match lake bottom elevation at 4,183 feet. This was done to ensure that flows north to south would pass through the causeway opening into the South Arm in accordance with the Bridge Evaluation Report.

Upon completion of the final design, UPRR submitted the drawings and associated data required by USACE, data such as volume of material placed below the ordinary high water level and the volumes associated with removing the material from the causeway and placement of fill to create the control berm.

3.7.2 Construction Sequencing and Schedule

UPRR would implement the project in accordance with the following activity sequencing and schedule and consistent with Conditions 1, 2 and 4-6 of the Water Quality Certification. Main construction activities would consist of three elements: constructing the temporary shoofly, constructing the bridge, and removing the temporary shoofly. These main construction activities are described in Table 3-2, including their approximate durations. Some of the activities can occur simultaneously; that is, UPRR can work on several activities at once.

Table 3-2. Main Construction Activities

Main Construction Activity	Anticipated Start Date	Duration (days)
Mobilize	10/1/2015	11
Build temporary work areas	10/1/2015	15
Shift rail to north, access road to south	10/27/2015	1
North Bridge Construction		
Drill piles, place concrete	11/2/2015	101
Build temporary platform for control berm	11/23/2015	18
Excavate embankment	2/18/2016	5
Install superstructure and backfill	3/28/2016	5
Construct control berm	11/30/2015	28
Grade shoofly, add ballast	4/1/2016	5
Transfer traffic to shoofly	4/18/2016	3
South Bridge Construction		
Drill pile locations, drive piles, place concrete	4/21/2016	73
Excavate embankment	7/6/2016	23
Place armor in bridge channel and slopes	7/12/2016	25
Install superstructure and backfill	8/16/2016	4
Excavate south channel	8/1/2016	15
Transfer to final alignment	9/16/2016	1
Remove temporary shoofly materials	9/23/2016	12
Delay—demobilize and re-mobilize	9/27/2016	42
Begin excavation of south access road	11/29/2016	2
Breach the south access road	12/1/2016	1
Finish south access road excavation	12/2/16	8
Construction completed	12/14/16	—

3.8 Maintenance Plan

UPRR will conduct maintenance activities through the permit monitoring period to ensure that the mitigation site remains functional once the initial construction is completed (Table 3-3).

Table 3-3. Five-Year Maintenance Activities

Maintenance Activity	Anticipated Frequency	Duration (days)
Visual bridge structure inspection	Annual	2

Regular structure maintenance activities would continue after the permit monitoring period as part of the UPRR bridge maintenance program.

3.9 Performance Standards

UPRR has developed performance standards to establish criteria that UPRR will apply to determine whether the compensatory mitigation project is achieving its mitigation objective. The main objective of UPRR's compensatory mitigation is to duplicate, as closely as possible, the aquatic function (water and salt transfer) lost due to the closure of the east and west culverts by constructing the new causeway opening associated with the compensatory mitigation bridge and control berm.

To develop appropriate performance standards, UPRR reviewed USACE's Uniform Performance Standards (UPS) procedures as described in *12505-SPD Regulatory Program Uniform Performance Standards for Compensatory Mitigation Requirements* (USACE 2012a). UPRR completed the UPS worksheet and determined that the following performance standards and criteria describe the mitigation activity. General information from the worksheet is summarized in Table 3-4 below, and the performance standards and targets are listed in Table 3-5 on page 30.

UPRR reviewed the USACE Attachment 12505.1, *Table of Uniform Performance Standards for Compensatory Mitigation Requirements*, to identify applicable performance standards (PS) based on aquatic resource type and performance standard categories. Of the 42 performance standards listed in the table, UPRR identified performance standards that describe the proposed mitigation activity and will be used to determine whether the mitigation is successful in meeting the objective.

Table 3-4. Information about the UPRR Mitigation Site per the Uniform Performance Standards Worksheet

Line No. ^a	Description	UPRR Site Mitigation
1	Mitigation site name	UPRR causeway bridge, MP 739.78
1	Cowardin/HGM (hydrogeomorphic) type	Non-wetland water of the U.S.
1	Habitat type	Saline deep open water
1	Site coordinates	Latitude 41.220833, Longitude -112.766389
1	Reference site	Not applicable
2	Mitigation objective	Specific aquatic resource
3	Mitigation type	Re-establishment
4	Primary type of site treatment	Hydrological manipulation
5	Aquatic resource type	Other: Saline open water
6	Performance standard categories	Physical, hydrologic, water quality(ecological)

^a Line number in the UPS worksheet.

3.9.1 Causeway Opening Geometry Performance Standards

The performance standards are focused on ensuring that the bridge structure and control berm are constructed and maintained as designed or with agreed-upon altered geometry and that the causeway opening remains unobstructed, free flowing, and protected against erosion. The performance standards also focus on maintaining the degree of inundation of the causeway opening (the water depth in the causeway opening in relation to varying lake levels) and the salt balance between the lake's North and South Arms. These standards are summarized in Table 3-5 below. Adaptive management measures that will be taken if the project is found to be not meeting these performance standards are described in Section 3.12, Adaptive Management Plan.

Table 3-5. Causeway Opening Geometry Performance Standards

PS No.	PS Type	Description	Measure and Frequency	Target
1	Physical	The mitigation bridge site will remain stable without excessive erosion or accumulation of debris.	Semi-annual for the first 2 years, then annual cross-section measurements at the mitigation site at four intervals, upstream and downstream, east and west	Average bridge site contours remain within 10% of as-built or agreed-upon altered geometry
2	Hydrologic	The causeway opening area and geometry (depth, width, and length) will be maintained to convey water between the North and South Arms at varying lake levels.	Semi-annual for the first 2 years, then annual cross-section measurements of the depth, width, and length to calculate average opening area and average contours	Average opening area remains within 10% of as-built or agreed-upon altered average geometry
3	Hydrologic	The causeway opening will be accessible to inundation of waters with no obvious restrictions present.	Measure and report quarterly water depth through the causeway opening	Average water depth remains within 10% of as-built or agreed-upon altered condition at specific lake levels
4	Hydrologic	The geometry and average grading contours of the bridge site and control berm will be maintained.	Semi-annual for the first 2 years, then annual measurements of control berm at appropriate intervals upstream and downstream	Average control berm contours remain within 10% of as-built or agreed-upon altered geometry

3.9.2 Water Quality (Salinity and Salt Balance) Performance Standard

Based on water and salt balance modeling, UPRR determined, with USACE and UDWQ concurrence, that the aquatic function of the causeway culverts would be best duplicated by constructing a 150-foot-long causeway opening with an invert elevation of 4,183 feet (UPRR 2014c, 2014d). That is, the water and salt transfer through the causeway between the North and South Arms of the lake with this causeway opening would best match the water and salt transfer through the causeway with the two free-flowing culverts under most modeling conditions. Just as lake salinities were the water quality parameters used in the modeling of impacts to evaluate the effects of replacing the culverts with the causeway opening, lake salinities and salt balance are the basis of the water quality performance standards in this CMMP. The water quality performance standard is summarized in Table 3-6 below.

Table 3-6. Water Quality (Salinity and Salt Balance) Performance Standard

PS No.	PS Type	Description	Measure and Frequency	Target
5	Water quality (salinity)	The causeway with the mitigation should provide water and salt transfer similar to that of the free-flowing culverts before closure, with South Arm salinity within the ranges predicted by the 2012 model and historic variability. Any project-caused variation of South Arm salinity outside those ranges will have a less-than-minimal adverse effect on lake aquatic resources that are protected by beneficial uses.	Sample and report quarterly lake salinity values at depth at one UGS location in the North Arm and three UGS locations in the South Arm	Project-caused changes to South Arm salinity remain within the historic and 2012 model ranges as defined or, if outside these ranges, have a less-than-minimal adverse effect on aquatic resources protected by beneficial uses

UGS = Utah Geological Survey

Salinity and salt balance performance standards are established in this CMMP to confirm that the project is meeting the mitigation objectives and, if it is not, to undertake adaptive management measures pursuant to Section 3.12, Adaptive Management Plan. Specifically, the monitoring and analysis described in Section 3.10, Monitoring and Reporting, will be conducted to determine whether the causeway with the mitigation is duplicating the water and salt transfer previously provided by the causeway with the free-flowing culverts as predicted in the modeling and, if not, whether any project-caused variation is having a significant adverse effect on beneficial uses and, therefore, an adaptive management adjustment to the causeway opening must be made.

UPRR has, in coordination with UDWQ, defined the water quality (salinity) performance standard based on South Arm salinity ranges for historic data and 2012 UPRR/USGS Model simulations. The analysis is summarized below and detailed in Appendix E.

Historic South Arm Salinity Range

UPRR used the Utah Geological Survey's (UGS) Great Salt Lake Brine Density Database to define the historic salinity range (UGS 2012) by analyzing the reported density and WSE data for the three Gilbert Bay locations of AC3, AS2, and FB2. These three sampling locations were chosen because of the amount of data collected consistently over the period of record (1966–2011) and because these sampling locations were used by USGS and UPRR to calibrate the water and salt balance model.

UPRR bathymetrically averaged the density results and then calculated the average South Arm salinity using the model relationship between density and salinity (see Appendix E). Using this method, UPRR developed a graph of average South Arm historic salinity compared to reported South Arm WSE taken on the day that UGS conducted the sampling.

A qualitative analysis of the uncertainty and error associated with the collection and analysis of the UGS data was conducted, and UPRR, with UDWQ concurrence, applied a 5% error to the averaged data to develop the graph shown in Figure 3-3 on page 33 and in Table 3-7 on page 34.

If lake WSEs rise or fall outside the historic range, UPRR will, in consultation with USACE and UDWQ, conduct an analysis as described in Section 3.10.3, Salinity and Salt Balance Reporting (Performance

Standard 5), paragraph 1 and then compare the salinity monitoring results to the extended historic data range. Using this methodology (bathymetric averaging and the USGS model empirical formula) to calculate average historic lake salinities, the historic lake salinity values (as shown in Figure 3-3 and Table 3-7) varied slightly from the historic salinity values reported in Figure 3-3 and Table 3-7 of the January 2015 CMMP and the ranges shown in Condition 3.A of the 401 Water Quality Certification (UPRR 2015a; UDWQ 2015). The use of a consistent calculation methodology facilitates a direct comparison between the historic data and the model data.

2012 UPRR/USGS Model South Arm Salinity Range

The 2012 UPRR/USGS water and salt balance model simulations computed lake salinities based on historic inflows and evaporation rates and causeway opening configurations for the period of 1987–2012 (UPRR 2014b). The UPRR Bridge Evaluation Report (UPRR 2014c) compared the lake salinities and salt loads for the free-flowing culvert simulation with the then-proposed bridge opening simulation. As summarized in Section 2.3, Summary of the Bridge Evaluation Report and Related Modeling, and Section 2.4, Summary of the Resource Evaluation Report, the Bridge Evaluation Report determined that the 150-foot-long causeway opening, with an invert elevation at 4,183 feet, would best meet the mitigation objectives; that is, it would duplicate the water and salt transfer functions of the free-flowing culverts as closely as possible at various lake levels, even with a slight change in salinity transfer over what would have occurred with the free-flowing culverts. The Resource Evaluation Report, which was based on that revised causeway opening and the resulting slight difference in salinity transfer, found that the project as revised would not cause a significant adverse effect on aquatic resources and beneficial uses.

The 2012 UPRR/USGS Model South Arm Salinity Range represents the lake salinities computed by the water and salt balance model free-flowing culvert and bridge simulations based on actual inflows and evaporation rates (1987–2012) as documented in the Bridge Evaluation Report. The model South Arm salinity range compared to the model-computed WSE is graphically represented in Figure 3-4 below and numerically represented in Table 3-7 on page 34.

Additionally, in consultation with UDWQ, UPRR has determined that, based on the degree of precision associated with the water and salt balance model and subsequent results, a 15% error or uncertainty range should be applied to the computed numeric model results (see Appendix E). This 15% error or uncertainty range has been included in the ranges described by Figure 3-4 below and Table 3-7 on page 34.

Figure 3-3. UPRR/UGS Historic South Arm Salinity Range

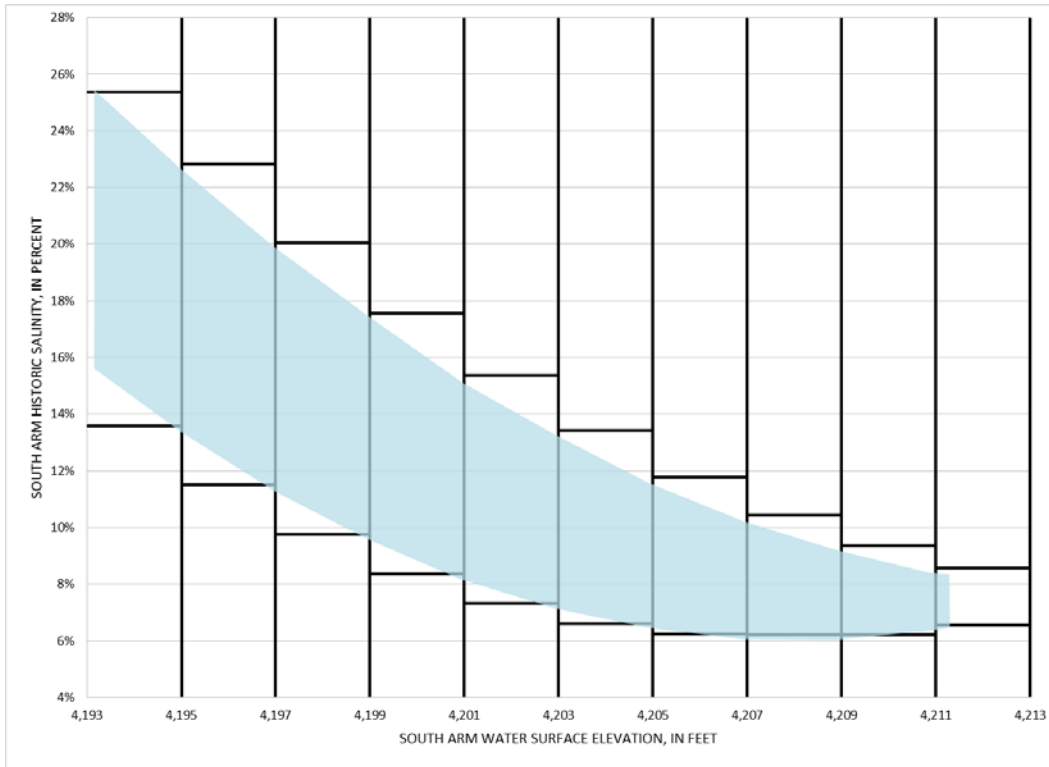
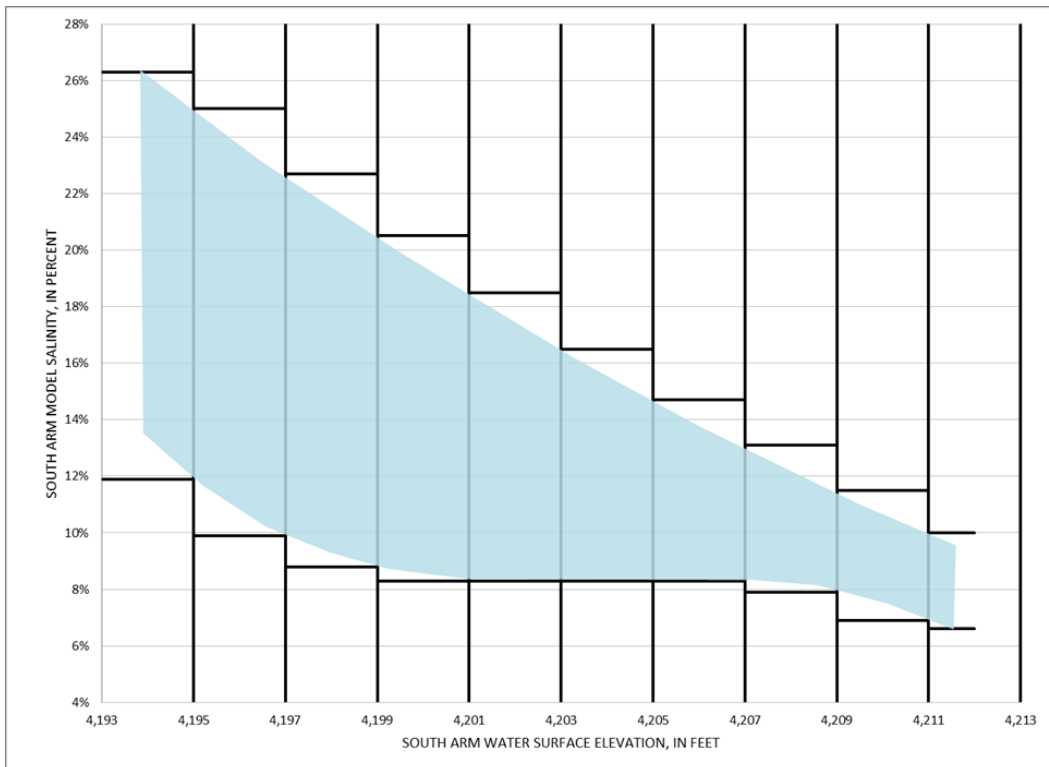

Figure 3-4. 2012 UPRR/USGS Water and Salt Balance Model South Arm Salinity Range



Historic and 2012 UPRR/USGS Model South Arm Salinity Range Results Tabulated

UPRR conducted the analysis of the data represented by Figure 3-3 and Figure 3-4 and above and organized the salinity ranges, by WSE, into a table format (Table 3-7).

Table 3-7. Salinity Performance Standard Range

South Arm Water Surface Elevation Range (feet)	UPRR/UGS Historic South Arm Salinity Range (%)	Modeled South Arm Salinity Range (%)	Combined Salinity Performance Standard Range (min. – max.)
4,193 up to 4,195	13.4 – 25.2	11.9 – 26.3	11.9 - 26.3
4,195 up to 4,197	11.5 – 22.9	9.9 – 25.0	9.9 – 25.0
4,197 up to 4,199	9.8 – 20.1	8.8 – 22.7	8.8 – 22.7
4,199 up to 4,201	8.4 – 17.6	8.3 – 20.5	8.3 – 20.5
4,201 up to 4,203	7.3 – 15.4	8.3 – 18.5	7.3 – 18.5
4,203 up to 4,205	6.6 – 13.4	8.3 – 16.5	6.6 – 16.5
4,205 up to 4,207	6.2 – 11.8	8.3 – 14.7	6.2 – 14.7
4,207 up to 4,209	6.2 – 10.4	7.9 – 13.1	6.2 - 13.1
4,209 up to 4,211	6.2 – 9.4	6.9 – 11.5	6.2 – 11.5

Note: The salinity ranges shown in Figure 3-3 and listed in this table are based on the UGS historical density data and the USGS model salinity empirical formula calculation to facilitate a direct comparison of the lake salinities between the UGS historic data and the UPRR/USGS model results. This methodology and analysis is further described in Appendix E.

3.10 Monitoring and Reporting

UPRR proposes to conduct the following project permit monitoring for 5 years, beginning the first quarter after the approved bridge is constructed and operating, to ensure that the compensatory mitigation is meeting its performance standards and, if not, to trigger adaptive management.

During the temporary east culvert closure period, UDWQ required, per condition 3 of its Utah 401 Water Quality Certification, that UPRR monitor the North and South Arms' ambient lake water quality and brine shrimp conditions during the temporary closure period (UDWQ 2013). Monitoring of water quality analytes and brine shrimp during the interim closure period is described in the UPRR Interim Monitoring Plan, Temporary Closure of the East Culvert, Great Salt Lake Causeway, Revised March 10, 2014. Interim monitoring will continue until the new causeway opening is constructed and free flowing, when at that time the interim monitoring plan will be superseded by the final monitoring plan, upon CMMP approval, as provided in the water quality certification.

If the causeway opening is adjusted pursuant to the adaptive management plan, as described in Section 3.12, Adaptive Management Plan, upon completion of the causeway opening adjustments made, UPRR will restart the 5-year monitoring period to demonstrate consistency with the salinity Performance Standard 5. The 5-year monitoring period will not be restarted for implementation of adaptive

management measures associated with keeping the causeway opening free flowing, as described in Section 3.12.1, Causeway Opening Geometry Adaptive Management, Performance Standards 1–4.

Within 120 days of receiving UDWQ approval of the Final CMMP, UPRR will develop a sampling and analysis plan (SAP) and quality assurance project plan (QAPP) meeting all EPA requirements for QAPPs (EPA/240/B-001/003) for the monitoring and additional data collection.

3.10.1 Monitoring Parameters

UPRR has determined the following monitoring parameters based on USACE’s mitigation plan template and the project’s performance standards. The purpose of the monitoring is three-fold:

1. Assess whether the bridge site is stable and the causeway opening area and geometry remain free flowing and unobstructed to meet project Performance Standards 1, 2, and 4.
2. Document whether the causeway opening is inundated by reporting lake levels and the water depth in the causeway opening to meet project Performance Standard 3.
3. Collect ambient water quality (salinity) data, compare with the established historic and 2012 model salinity ranges, and, if needed, update the salt balance model and impacts analysis to confirm that the project is meeting its mitigation objectives as described in project Performance Standard 5.

These three purposes are described further in Table 3-8. If the results of the monitoring plan reflect that the project is not meeting the performance standards, UPRR will submit a Notification of Monitoring Results That Trigger Adaptive Management as described in Section 3.10.2, Reports and Notifications, and adaptive management measures will be carried out pursuant to Section 3.12, Adaptive Management Plan.

For the water quality monitoring element of this CMMP, salinity (represented by density) has been identified as the exclusive water quality monitoring parameter based on the following considerations:

- UDWQ has stated that the use of the water and salt balance model has been accepted for determining the mitigation and that salinity or salt load is an appropriate surrogate for parameters of concern on this project (UDWQ 2014).
- The water quality evaluation provided in the Resource Evaluation Report (UPRR 2014d) concluded that, with no significant change in salinity caused by the project, the factors that affect the fate and transport of specific water quality parameters would not be changed, such that there would be no significant adverse effect on beneficial uses.
- The project would not discharge any pollutants of concern that would change the ambient lake concentrations.

Table 3-8. Monitoring Parameters

Purpose (PS No.)	Description	Measure and Frequency
Stability of the mitigation site (1, 2, and 4)	Assess whether the mitigation site, causeway opening average area and geometry, and control berm geometry remain stable and there is not excessive erosion or accumulation of debris.	Semi-annual for the first 2 years, then annual cross-section measurements of the mitigation site at four intervals, upstream and downstream through the causeway opening, to calculate average opening area and average site contours.
Hydrology (3)	Assess whether the causeway opening remains open to inundation of waters with no significant restrictions present.	Measure and report quarterly average water depth through the causeway opening.
Water quality (salinity) (5)	Monitor ambient lake parameters and compare salinity results with UPRR/UGS historic and 2012 model salinity ranges, and, when needed to determine consistency with the performance standard, update the salt balance model and impacts analysis to confirm that the project is meeting its mitigation objectives, that is, that the causeway with the mitigation provides water and salt transfer similar to that of the causeway with the free-flowing culverts before closure and that any project-caused variation from historic and modeled salinities does not adversely impact lake aquatic resources protected by beneficial uses.	Sample and report quarterly lake salinity values at depth at one UGS location in the North Arm and three UGS locations in the South Arm.

UGS = Utah Geological Survey

Table 3-9 lists the water quality parameters and constituents to be measured quarterly throughout the permit monitoring period. These measurements will support the determination of the ambient lake salinity at each of the monitoring locations.

Table 3-9. Monitoring Parameter Methods, Detection Limits, Reporting Limits, and Laboratory Hold Times

PS Number	Parameter	Method	Method Detection Limit	Method Reporting Limit	Hold Time
Field Measurements					
3	Total water depth	Troll 9500 field measurement	—	0.1 m	Field
5	Specific conductivity	SM 2510A	0.001 µmhos	0.001 µmhos	Field profile
5	Temperature	SM 2520	0.1 °C	0.1 °C	Field profile
5	Specific gravity	ASTM 1429 ^a	0.001 (unitless)	0.001 (unitless)	—
Laboratory Analyses					
5	Density	SM 2710F	—	0.001 g/mL	7 days
5	Total dissolved solids	SM 2540C	—	5 mg/L	7 days

°C = degrees Celsius; µmhos = micromhos; ASTM = American Society for Testing and Materials; g/mL = grams per milliliter; m = meters; mg/L = milligrams per liter; PS = performance standard; SM = Standard Methods for the Examination of Water and Wastewater

^a Specific Gravity Determinations Using a Hydrometer

Sample parameters and frequency are identified in Table 3-10. Data will be collected at all monitoring locations similarly.

Table 3-10. Monitoring Parameters and Frequency

PS Number	Parameter	Number and Sample Depth	Frequency	Field Duplicate	Field Blank	Equipment Rinsate
3	Total water depth	One measurement taken from water surface to bottom of lake	Quarterly per year	NA	NA	NA
5	Conductivity, temperature	Vertical profile; measurements taken <i>in situ</i> every 5 feet	Quarterly per year	NA	NA	NA
5	Total dissolved solids, density, specific gravity	Vertical profile; grab samples taken every 5 feet	Quarterly per year	10% of samples	10% of samples	10% of samples

NA = not applicable; PS = performance standard

The approved water-monitoring locations for lake salinity are shown in Figure 3-5 below. These sample locations were chosen, in coordination with UDWQ, because they are coincident with current UGS sampling locations. In this way, the monitoring data collected at the South Arm sampling locations can be compared directly to the historic South Arm salinity range determined by the analysis of the UGS data collected at the same locations. Figure 3-5 shows the UPRR water-monitoring locations in relation to the other agency water-monitoring locations including UGS and UDWQ and the lake bathymetry.

UPRR will conduct the following actions on the monitoring data:

- Average the discrete density data, which will be used to calculate an average South Arm salinity, in accordance with USGS methodology as described in Appendix E. This average South Arm salinity will then be compared to the salinity performance standard as shown in Section 3.9.2, Water Quality (Salinity and Salt Balance) Performance Standard.
- Calculate discrete North Arm salinity values from the North Arm discrete density values.

Once salinities are calculated, the data for the South Arm will be compared with the historic and modeled salinity ranges as described in Table 3-7, Salinity Performance Standard Range, on page 34.

Figure 3-5. UPRR Water-Monitoring Locations In Relation to Other Water-Monitoring Locations

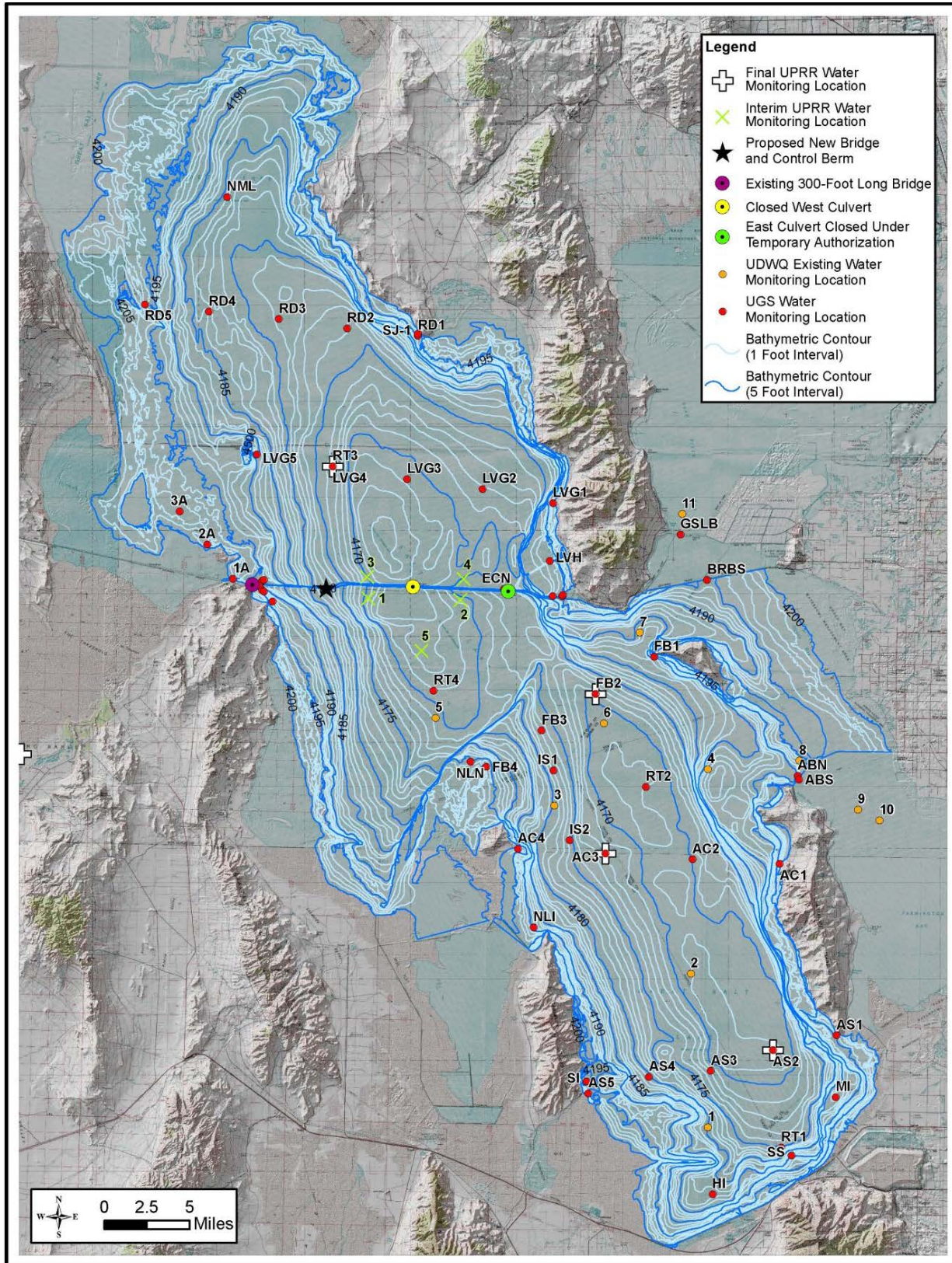

3.10.2 Reports and Notifications

Quarterly Data Reports. Within 45 days of the monitoring event, UPRR will provide quarterly monitoring data reports to USACE and UDWQ containing the laboratory data and measurements made for that quarter. In addition to the monitoring data, the quarterly reports will include the additional field and laboratory data and measurements collected as described in Section 3.11, Additional Data Collection.

Annual Reports. UPRR will submit annual monitoring reports to USACE and UDWQ to provide information regarding the mitigation site conditions and how the monitoring results support the performance standards. Annual monitoring reports will be submitted on February 1 of each year following the reporting period. Each report will contain the following information:

- Monitoring team and dates of the events
- Brief description of the mitigation bridge construction and completion in relation to the monitoring event
- Narrative as to the current condition of the mitigation site, and any changes from the as-built condition as provided by data collection
- Performance standard progress assessment: whether the monitoring results reflect that the project is meeting the performance standards or have triggered any adaptive management measures pursuant to Section 3.12, Adaptive Management Plan, and, if so, the status of the adaptive management effort (UPRR will be coordinating adaptive management steps with USACE and UDWQ separately)
- Dates of any corrective or maintenance activities conducted since the previous report
- Summary of monitoring event data results and photographs

Annual reports will require UDWQ approval. In addition to the information described above, the annual monitoring reports will include the additional data collected as described in Section 3.11, Additional Data Collection. As required by Certification Condition 3.G, if UDWQ does not approve the annual report, UDWQ will provide UPRR with a detailed description of the deficiencies and UPRR will submit a revised report addressing these deficiencies within 60 days of receiving UDWQ's description, unless UDWQ approves an alternative time period.

Notifications of Monitoring Results and Analysis That Trigger Adaptive Management. In addition to submitting the scheduled reports described herein, if the results of the monitoring plan show that the performance standards set out in Section 3.9.1, Causeway Opening Geometry Performance Standards, are not being met, UPRR will so notify USACE and UDWQ and will undertake the actions described in Section 3.12.1, Causeway Opening Geometry Adaptive Management.

Where the results of ambient salinity monitoring are outside the salinity performance standard ranges in Table 3-7, Salinity Performance Standard Range, and described in Section 3.9.2, Water Quality (Salinity and Salt Balance) Performance Standard, UPRR will undertake the modeling update and impacts assessment described in Section 3.10.3, Salinity and Salt Balance Reporting (Performance Standard 5). If the results of that process reflect that adaptive management is necessary, UPRR will so notify USACE and UDWQ and will undertake the measures described in Section 3.12.2, Salinity and Salt Balance Adaptive Management.

Completion Report. After no less than 5 years of monitoring results, following any adaptive management–related causeway adjustment made pursuant to Section 3.12.2, Salinity and Salt Balance Adaptive Management, demonstrating that the salinity performance standards are being met and trends indicating that they will continue to be met in the future, UPRR will submit a completion report, with a request for cessation of monitoring and adaptive management, for USACE’s and UDWQ’s approval. The report will describe the monitoring results since construction of the causeway opening and will describe any long-term changes in flow and salt transfer associated with the project in relation to the mitigation objectives, lake salinity, beneficial uses, antidegradation policy, and numeric and narrative standards. In addition, the completion report will provide a basis for cessation of monitoring and adaptive management and will include a copy of the executed long-term management Memorandum of Understanding (MOU) between UPRR, UDWQ, and USACE. This completion report will provide the basis for USACE and UDWQ to determine whether the monitoring and adaptive management period is complete and, if so, to grant UPRR’s request for cessation of monitoring and adaptive management. UDWQ will provide a 60-day public notice prior to determining whether to grant UPRR’s request for cessation of monitoring. As required by Certification Condition 3.D, if UDWQ does not approve the completion report, UDWQ will provide UPRR with a detailed description of the deficiencies and UPRR will submit a revised report addressing these deficiencies within 60 days of receiving UDWQ’s description, unless UDWQ approves an alternative time period.

3.10.3 Salinity and Salt Balance Reporting (Performance Standard 5)

This section describes the process UPRR will follow, using the results of the ambient salinity monitoring, to determine whether the project is meeting the salinity performance standard (Performance Standard 5).

1. Compare Salinity Monitoring Results with the 2012 Model and Historic Salinity Ranges.

UPRR will compare the ambient salinity monitoring results for the South Arm with the 2012 model range and historic range described in Section 3.9.2, Water Quality (Salinity and Salt Balance) Performance Standard.

In the event that lake levels (WSEs) rise or fall outside the historic range described in Section 3.9, Performance Standards, for two consecutive quarters or after one quarter when the salinity from the previous quarter was outside the salinity performance standard ranges, UPRR will, in consultation with USACE and UDWQ:

1. Update and extend the 2012 UPRR/USGS Model after the second consecutive quarter using the same methodology used to derive the original salinity performance standard ranges (salinity ranges) in order to calculate a salinity range at the new elevation within 90 days of the determination; or
2. With USACE and UDWQ approval, use alternative methodology(ies), such as extrapolation of the historic data, to determine a salinity range at the new elevation.

UPRR will then compare the salinity monitoring results to the extended ranges.

2. Where Ambient Monitoring Results Are Within the Modeled and Historic (or Extended Historic) Salinity Ranges, Report and Continue Monitoring.

Where South Arm ambient salinity monitoring results are within the 2012 model and historic (or extended historic) salinity ranges, such a result indicates that the project has not caused a change to the ambient salinities from what they would have been with the culverts in place; that result indicates consistency with the mitigation objective of duplicating the aquatic functions of the now-closed culverts. UPRR's analysis presented in the Resource Evaluation Report concluded that project-caused salinity variations within the historic lake salinity range would not adversely affect the lake's beneficial uses. Using salinity as a surrogate for water quality, with no significant change in water quality caused by the project, there would be no significant adverse effect on the lake's beneficial uses.

Accordingly, if the ambient South Arm salinity monitoring results are within these ranges, the monitoring data, analyses, salinity comparison results, and determination of consistency with the performance standard will be documented in the quarterly and annual reports. No supplemental modeling and impacts assessment will be required, and UPRR will continue with quarterly ambient lake salinity monitoring and reporting in accordance with this CMMP.

3. Where Ambient Monitoring Results Are Outside Modeled and Historic (or Extended Historic) Salinity Ranges, Update Model and Resource Impacts Assessment.

If the ambient salinity monitoring results are outside the established salinity ranges (described in Section 3.9.2, Water Quality (Salinity and Salt Balance) Performance Standard), this result is an indication that potentially adverse ambient South Arm salinity conditions exist. However, just the comparison of monitoring data with modeled and historical data does not reveal the cause of such conditions and, therefore, whether the project is meeting the salinity performance standard. Additional steps must be taken to determine whether the project has caused the variation and, if so, whether that variation is having significant adverse effects on aquatic resources protected by the lake's beneficial uses.

If the South Arm ambient salinity monitoring results are outside the established 2012 model salinity range and historic (or extended historic) salinity range for two consecutive quarterly monitoring events, UPRR will notify USACE and UDWQ and initiate the update of the salt balance model and the resource impacts assessment as described herein. The purpose of this analysis will be to determine whether the variations in ambient salinity levels are caused by the project, adversely affect aquatic resources (for example, brine shrimp) protected by beneficial uses, and, therefore, do not meet salinity Performance Standard 5.

It is well documented that the WSEs and salinities of the lake vary by season, year, and decade. Surface inflows, WSEs, salinities, salt loads, weather patterns, low lake levels, and industry infrastructure and operations all influence the water and salt transfer between Gilbert and Gunnison Bays. For this reason, monitoring results from a full hydrological cycle (that is, four consecutive quarterly monitoring events) are necessary in order to complete the modeling and impacts analysis that must be carried out in order to determine whether a causeway opening adjustment should be made. However, to facilitate timely, efficient, and fully informed determinations of consistency with the performance standard, UPRR will, in coordination with USACE and UDWQ, start the water and salt balance model update and calibration process as well as the impacts analysis after two consecutive monitoring events result in variations outside the 2012 model and historic salinity ranges to determine whether the project has adversely affected the lake's beneficial uses and, therefore, does not meet the performance standard.

Model Update and Calibration. Once this process is initiated, UPRR will begin updating the calibrated 2012 UPRR/USGS Water and Salt Balance Model through the current year in coordination with USACE and UDWQ. Starting with the 2012 actual lake conditions, the lake hydrology, precipitation, evaporation, and other water and salt balance model input parameters will be generated to simulate lake conditions through the current year (or as close to current conditions as the data allow). However, if the results of the third or fourth consecutive quarterly ambient salinity monitoring events are within the historic and 2012 model ranges, UPRR will notify USACE and UDWQ that this updated modeling and impacts assessment will be suspended, and monitoring will continue through the permit monitoring period.

If the results of the third and fourth consecutive quarterly ambient salinity monitoring results remain outside the ranges predicted by the 2012 UPRR/USGS Model or historic variation, the data collected will be added to extend and update the model through the current year. The updated modeling and impacts assessment will be completed within 2 months of receiving the fourth quarter of consecutive ambient salinity monitoring outside the 2012 modeled and historic ranges.

The updated model will include the actual physical condition of the causeway openings (east culvert closure and new causeway opening). After the actual physical and hydrologic conditions are input into the updated model, UPRR will calibrate the new water balance and salt balance model, following similar procedures as those described in the Final Modeling Report, step 2 (UPRR 2014b). The model update will use the additional data collected pursuant to Section 3.11, Additional Data Collection. The 2012 UPRR/USGS Model update will include the following:

1. Verify the equations used in the 2012 UPRR/USGS Model to simulate bidirectional water and salt transfer through the openings in the causeway using available monitoring data, if appropriate and feasible within the approved project's permitting objectives and regulatory framework, or conduct sensitivity analysis.
2. Review methods and results from latest Great Salt Lake modeling efforts, including the UDFSL Great Salt Lake Integrated Water Resources Model, and incorporate improvements into the model if consistent and appropriate within the approved project's permitting objectives and regulatory framework.

UPRR will run the updated water and salt balance model with actual lake and causeway characteristics and will compare the results to the free-flowing culvert simulation for lake salinity and salt loads. The difference in lake salinity between the model simulations, the new causeway opening, and the free-flowing culverts will be calculated for each quarter and averaged. An average difference in salinities of no more than 2% absolute difference or 10% relative difference, whichever is less, will be considered to support the determination that the observed deviations of salinity from the salinity performance standard ranges are not caused by the project, and the project (the replacement of the culverts with the new bridge and causeway opening) is in fact meeting the mitigation objective by duplicating, as closely as possible, the water and salt transfer that the culverts would have provided if the culverts had continued functioning (open and free flowing at 2012 elevations) instead of being closed and replaced by the bridge and causeway opening. Should salinity variations be greater than these percentages, USACE and UDWQ will review UPRR's evaluation and will determine whether the project is meeting the mitigation objective. That review and evaluation will take into account modeling certainty and context, including the conclusions of the Bridge Evaluation Report that the slight variation of water and salt transfer predicted for the 150-foot-long causeway opening in relation to that predicted for the culverts, would satisfy the

mitigation objective, that is, the opening with the slight variation would duplicate the water and salt transfer “as closely as possible.”

Aquatic Resource Impacts Assessment. As described in Section 2.1, Analytical Approach, UPRR received direction from USACE, in its February 2013 letters describing the project’s mitigation objectives, that the compensatory mitigation project must (1) replace the aquatic functions of the east and west culverts (transfer of water and salt) and (2) result in less-than-minimal effects on aquatic resources. The model update will address the issue of whether the project is in fact replacing the culverts’ aquatic functions (by not causing a significant variation of South Arm salinities from what the culverts would have produced; that is, outside what the model predicted they would do), and the resource impacts assessment will determine whether any such variation would adversely affect aquatic resources that rely on the lake’s beneficial uses.

A project-caused variation of South Arm salinities outside the model ranges also would be outside the scope of the UPRR Resource Evaluation Report (UPRR 2014d), which found that variations within the model simulations and historical variability are not likely to result in significant adverse effects on the lake’s beneficial uses. Therefore, a project-caused variation of salinities outside the model ranges must be evaluated individually to determine whether it significantly adversely affects lake’s aquatic resources and, therefore, its beneficial uses.

As described in more detail in the Resource Evaluation Report, the designated beneficial uses in the project area are:

- **Gilbert Bay (part of the South Arm):** Protected for frequent primary and secondary contact recreation, waterfowl, shore birds, and other water-oriented wildlife including their necessary food chain.
- **Gunnison Bay (the North Arm):** Protected for infrequent primary and secondary contact recreation, waterfowl, shore birds, and other water-oriented wildlife including their necessary food chain.

The impacts assessment would be conducted in coordination with USACE and UDWQ consistent with the methodology and analytical approach conducted for aquatic resources in the Resource Evaluation Report, with the focus being on the evaluation of potential adverse effects on the lake’s aquatic resources that are protected by beneficial-use designations resulting from project-caused changes in salinity outside the historical and model simulation ranges. Project-caused adverse effects on these aquatic resources would be considered a greater-than-minimal effect under the requirements described above.

Brine shrimp and brine flies are part of the wildlife food chain of the lake, and the lake’s beneficial uses include protections for shore birds and other water-oriented wildlife, including their necessary food chain. Therefore, the impacts assessment will focus mainly on project-caused salinity effects on the factors (food source, lifecycle, and predators) that affect brine shrimp and brine flies that exist in the Gilbert Bay. Brine shrimp are a keystone species in the Great Salt Lake food chain; they rely on phytoplankton for food and are a food source for corixids and migratory birds (UPRR 2014d) and are, therefore, representative of the aquatic resources of the South Arm. Accordingly, the project would have a significant adverse effect if it were to change the long-term range of salinity in the South Arm such that the change adversely affects brine shrimp and/or brine fly fecundity and survival and therefore adversely affects beneficial uses.

The evaluation will compare the measured Gilbert Bay data collected by UPRR during the monitoring period (or model simulation results with the causeway opening in place) to published literature regarding the presence of and lifecycle influences on brine shrimp and brine flies, as represented by salinity ranges.

Lifecycle influences on brine shrimp populations include food source availability (phytoplankton) and predators associated with changes of salinities outside the historic and modeled ranges. The evaluation will also review scientific studies and data that consider how salinities of the lake may influence the habitat of brine shrimp, since the brine shrimp have been documented to move between the bays of the lake based on favorable conditions.

If a project-caused variation outside the model salinity ranges is found to adversely affect the lake's brine shrimp and brine flies (aquatic resources) that are protected by the lake's beneficial uses, the project would be considered to have a greater-than-minimal adverse effect.

Conclusions and Notifications. If UPRR, in consultation with USACE and UDWQ, concludes, based on the updated model and aquatic resource impacts assessment, that a variation in South Arm salinities outside the model salinity range is a result of the project and has adversely affected aquatic resources protected by the lake's beneficial uses, UPRR will submit a Notification of Monitoring and Analysis Results That Trigger Adaptive Management as described in Section 3.10.2, Reports and Notifications. UPRR will include an adaptive management/causeway opening adjustment proposal with this report, as described in Section 3.12.2, Salinity and Salt Balance Adaptive Management. This report and adaptive management/causeway adjustment proposal will be submitted for USACE approval and UDWQ review, including any public comment as determined by the UDWQ Director, and approval within 2 months of receiving the fourth consecutive quarter monitoring results that triggers completion of the modeling and impacts assessment process in Section 3.10.3, Salinity and Salt Balance Reporting (Performance Standard 5).

If the project has not caused salinity variations outside the model ranges (that is, the monitoring data results are a result of influences [such as inflows, weather, and/or other industry infrastructure and operations] other than the permanent closure of the east culvert and implementation of mitigation), or if a project-caused variation has not adversely affected aquatic resources protected by beneficial uses (i.e., the lake's beneficial uses are and will be protected under the new salinity regime resulting from this variation), then the project will be considered to be meeting the salinity Performance Standard 5, and no adaptive management measures will be required. UPRR will describe that conclusion in writing to USACE and UDWQ for their concurrence within 2 months of receiving monitoring results from the four consecutive quarters that are outside the established salinity ranges. UPRR will continue with monitoring as described in the monitoring plan for the remainder of the permit monitoring period.

3.11 Additional Data Collection

UPRR proposes to collect and report additional data for the permit monitoring period (Table 3-11). These additional data would be collected and reported to assist with future lake modeling or lake-management activities. The additional data would not be used to determine compliance with performance standards but rather would be used if additional water and salt balance modeling is required—for example, as part of the updated model and impacts assessment described in Section 3.10.3, Salinity and Salt Balance Reporting (Performance Standard 5). With UDWQ input, UPRR determined that monthly additional data collection frequency is appropriate, since past flow measurements through the culverts and the existing 300-foot-long bridge were taken periodically and meet the monthly data input needs of the model.

Table 3-11. Additional Data Collection Parameters

Topic	Measure/Frequency
Flow	Collect data to calculate monthly bidirectional water flows through the causeway opening
Deep brine layer	Report the presence of the Gilbert Bay deep brine layer at monitoring locations
Lake levels	Report North and South Arm WSE levels on monitoring dates, as reported on the USGS lake website, for context

The spot flow measurements taken at the culvert locations and existing 300-foot-long bridge locations were taken during calm weather and lake conditions to collect data during times when the flows were most stable and equalized for specific WSE and salinity conditions. In this manner, spot measurements may be used to support the model calibration process and determine model error. UPRR proposes to follow the same flow monitoring protocol as USGS and the Utah Department of Natural Resources by conducting spot measurements and determine the bidirectional flow for that monitoring date.

The additional data collection results will be included in the quarterly and annual reports and submitted to the agencies during the permit monitoring period.

Table 3-12 lists the additional data to be collected monthly throughout the permit monitoring period. These measurements will support future water and salt balance modeling, if required. In addition, Table 3-13 below lists the additional data to be collected to support the calculation of bidirectional flow through the new causeway opening. These monthly measurements will be collected at the site of the new bridge structure and at the same time as bidirectional flow measurements to assist with the determination of the flow in each direction through the new causeway opening. These measurements and subsequent calculations will be used to support future water and salt balance modeling and used in verifying the model flow computations if required.

Table 3-12. Additional Data Collection Parameters

Parameter	Method ^a	Method Detection Limit	Method Reporting Limit	Hold Time
<i>Field Measurements – Surface Water</i>				
Lake elevation ^a	USGS automated gage	—	—	—
Depth to deep brine layer ^b	Troll 9500 field measurement	—	0.1 m	Field
Total water depth	—	—	0.1 m	Field
Temperature	SM 2520	0.1 °C	0.1 °C	Field profile

°C = degrees Celsius; m = meters; SM = Standard Methods for the Examination of Water and Wastewater; USGS = U.S. Geological Survey

^a Water level data collected from USGS stations at Saltair Beach State Park and Little Valley Boat Harbor will also be compiled from ut.water.usgs.gov/greatsaltlake/elevations.

^b *Brine layer depth* refers to the vertical zone in a water column in which salinity changes rapidly with depth. Determined from conductivity and TDS data.

Table 3-13. Additional Data To Be Collected to Calculate Bidirectional Flow

Parameter	Method ^a	Method Detection Limit	Method Reporting Limit	Hold Time
Field Measurements – Surface Water				
Depth to deep brine layer ^b	Troll 9500 field measurement	—	0.1 m	Field
Total water depth	—	—	0.1 m	Field
Temperature	SM 2520	0.1 °C	0.1 °C	Field profile
Specific gravity	ASTM 1429 ^c	0.001 (unitless)	0.001 (unitless)	—
Laboratory Analyses – Surface Water				
Density	SM 2710F	—	0.001 g/mL	7 days
Total dissolved solids	SM 2540C	—	5 mg/L	7 days
Bidirectional Flow through Causeway Opening				
North-to-south velocity	ADCP field measurement	NA	NA	NA
South-to-north velocity	ADCP field measurement	NA	NA	NA
North-to-south flow	Calculated	NA	NA	NA
South-to-north flow	Calculated	NA	NA	NA

°C = degrees Celsius; ADCP = Acoustic Doppler Current Profiler; ASTM = American Society for Testing and Materials; g/mL = grams per milliliter; m = meters; mg/L = milligrams per liter; NA = not applicable; SM = Standard Methods for the Examination of Water and Wastewater

^a Laboratory analytical method or field equipment.

^b *Deep brine layer depth* refers to the vertical zone in a water column in which salinity changes rapidly with depth.

^c Specific Gravity Determinations Using a Hydrometer

3.12 Adaptive Management Plan

To facilitate adaptive management activities identified as necessary during the permit monitoring period and future lake management activities that may be undertaken after the permit monitoring period, UPRR is proposing to construct a 180-foot-long bridge structure with an adjacent earthen control berm to create the required 150-foot-long causeway opening. With this design, adjustments to the causeway opening may be made to increase or decrease the causeway opening length, or increase or decrease the control berm invert elevation, within the ranges allowed by the bridge structure design.

UPRR will implement adaptive management as described in this section following the submission of the Notification of Monitoring Results That Trigger Adaptive Management as described in Section 3.10, Monitoring and Reporting. Note that the salinity ranges shown in Figure 3-3 above and listed in Table 3-13 above are based on the UGS historical density data and the USGS model salinity empirical formula calculation to facilitate a direct comparison of the lake salinities between the UGS historic data and the UPRR/USGS model results. This methodology and analysis is further described in Appendix E.

3.12.1 Causeway Opening Geometry Adaptive Management

This section describes measures to be taken in a stepwise process to determine whether the causeway opening geometry has become restricted or obstructed by excessive erosion or whether debris has accumulated. This section also describes measures that may be implemented if UPRR or USACE and UDWQ, upon review of UPRR's data report, determine that the causeway opening needs to be increased and/or decreased to duplicate the as-built conditions.

UPRR will implement the following action measures in progressive steps if monitoring survey data indicate that the causeway opening geometry is outside the as-built conditions or accepted geometry and therefore does not meet the performance standard. The as-built conditions, including average opening area and control berm contours, or accepted geometry, will be set by survey data collected after the bridge structure and control berm are constructed and operating. Nominally, the opening for the causeway is described as 150 feet wide and has an invert elevation of 4,183 feet, which will be set by the control berm. The bridge structure will have a nominal opening of 180 feet and an invert elevation of 4,178 feet. These dimensions are shown in Figure 3-1, Approved Bridge and Causeway Opening Geometry, on page 25 and Figure 3-2, Approved Bridge and Control Berm Plan View, on page 26.

1. Review quarterly water depth data and determine the extent of the causeway opening (water flow capacity) restriction or enlargement (Performance Standard 3).

If UPRR determines that the quarterly average water depth data show an enlargement or restriction of the flow through the causeway opening, UPRR will examine the data to determine the extent of the effect. If monitoring data suggest that the inundation (water depth) under the bridge is excessive or limited (within a variation of 10%), UPRR will examine the data to determine the extent of the effect. Once the extents are identified, UPRR will prepare a plan to remediate the deviation. This remediation may consist of rebuilding the causeway opening invert so that the invert elevation is restored to its original as-built condition.

2. Review survey data and the extents of the restriction or enlargement of the control berm and causeway opening to determine the cause of the deviation (Performance Standards 1, 2, and 4).

UPRR will review the annual data and attempt to determine what caused the control berm and/or causeway opening to fill in or enlarge. Possible causes are debris accumulation caused by wind, erosion caused by wind, and excessive velocities through the causeway opening resulting in scour holes. If an event or situation caused the restriction or enlargement of the control berm and causeway opening, UPRR will, in coordination with UDWQ and USACE, design and implement a mitigation measure to attempt to prevent future similar effects on the control berm and causeway opening. Potential mitigation measures include placing additional rip-rap, increasing the size and amount of the rip-rap, removing the accumulated debris, and stabilizing the source of the debris.

What is rip-rap?

Rip-rap is rocks that are placed to prevent scouring due to erosion.

3. Coordinate with agencies.

UPRR will coordinate with USACE and UDWQ to review the plan to remediate the restriction or enlargement of the causeway opening and to implement any mitigation measure to prevent future similar effects on the causeway opening. Upon review and approval of the agencies, UPRR will implement the plan and conduct a survey afterward to confirm that the causeway opening will meet performance standards, which is that the causeway opening is within 10% of the as-built conditions.

UPRR will develop and submit to the agencies the remediation plan, if necessary, within 1 month of obtaining the quarterly water depth measurements or annual survey results and would implement the plan within 2 months of receiving the agencies' approval of the plan. Adaptive measures conducted to date will be documented in the annual monitoring report, as described in Section 3.10.2, Reports and Notifications.

3.12.2 Salinity and Salt Balance Adaptive Management

UPRR will implement the following measures to adjust the causeway opening when, based on the results of the analysis described in Section 3.10.3, Salinity and Salt Balance Reporting (Performance Standard 5), UPRR, in consultation with USACE and UDWQ, determines that the project has caused a variation in South Arm salinities that adversely affects aquatic resources (brine shrimp) and therefore is not meeting the salinity performance standard (Performance Standard 5).

Specifically, UPRR will, using the updated model, develop and propose, for USACE and UDWQ approval, modifications to the adjustable features of the causeway opening (control berm and excavated channel outside of the bridge structure) to modify the new opening's relative contribution to the overall water and salt transfer and meet the performance standards.

In coordination with USACE and UDWQ, UPRR will evaluate the following physical changes to the control berm that effectively creates the 150-foot-long opening in the causeway through the 180-foot-long bridge structure:

- If the analysis indicates that the South Arm is losing salt compared to the free-flowing culvert simulations, UPRR will propose lowering the existing control berm invert to increase the north-to-south flow through the breach and the resulting ratio of flows. UPRR proposes that lowering the invert will be conducted in coordination with model results. The maximum the invert will be lowered is 5 feet (to elevation 4,178 feet) to match lake bottom conditions within the immediate area of the bridge.
- If the analysis indicates that the South Arm is gaining salt compared to the free-flowing culvert simulation, UPRR will propose raising the existing control berm invert to decrease the north-to-south flow through the breach and the resulting ratio of flows. UPRR proposes that raising the invert is conducted in coordination with model results.
- In addition to the potential adjustments that may be made to the invert of the control berm, the width of the opening through the control berm itself may be enlarged or reduced (up to the limits of the bridge structure) so that the bidirectional flows through the causeway opening can be increased or decreased.

These measures will be implemented on the adjustable features of the causeway opening that is shown on the bridge plans in Appendix D and Figure 3-6 and Figure 3-7 below. Implementing these measures would not include modifying the bridge structure, only the earthen control berm and excavated channel. The control berm would be located to the immediate north of the bridge structure, and the excavated channel would extend from the area under the bridge structure to the south, as shown on the drawings in Appendix D.

UPRR would submit for USACE and UDWQ approval the adaptive management/causeway adjustment proposal with its Notification of Monitoring Results and Analysis That Trigger Adaptive Management Report [within 2 months of receiving monitoring results from the four consecutive quarters that are outside the established salinity ranges as described in Section 3.10.3, Salinity and Salt Balance Reporting (Performance Standard 5)]. The adjustment to the opening would be made within 2 months of receiving USACE and UDWQ approval of the causeway opening adjustment proposal (UDWQ may provide a public notice and comment on the adaptive management proposal prior to determining whether to approval UPRR's causeway opening adjustment proposal).

Figure 3-6. Bridge, Excavated Channel and Earthen Control Berm (Isometric View Looking Southeast)

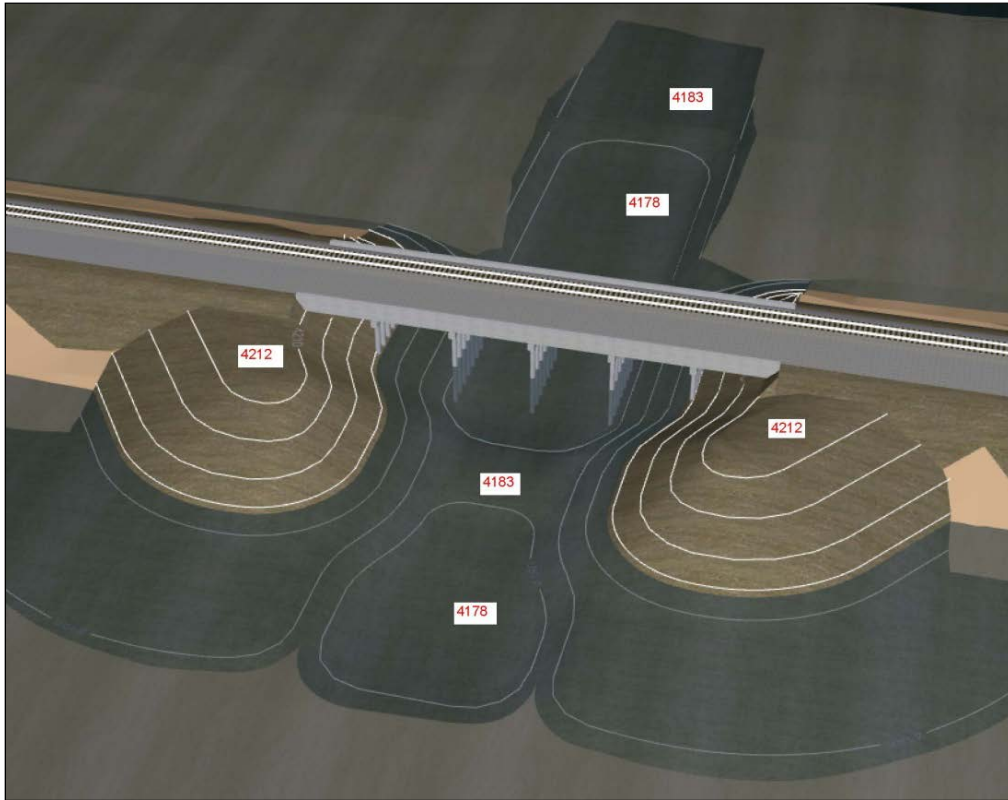
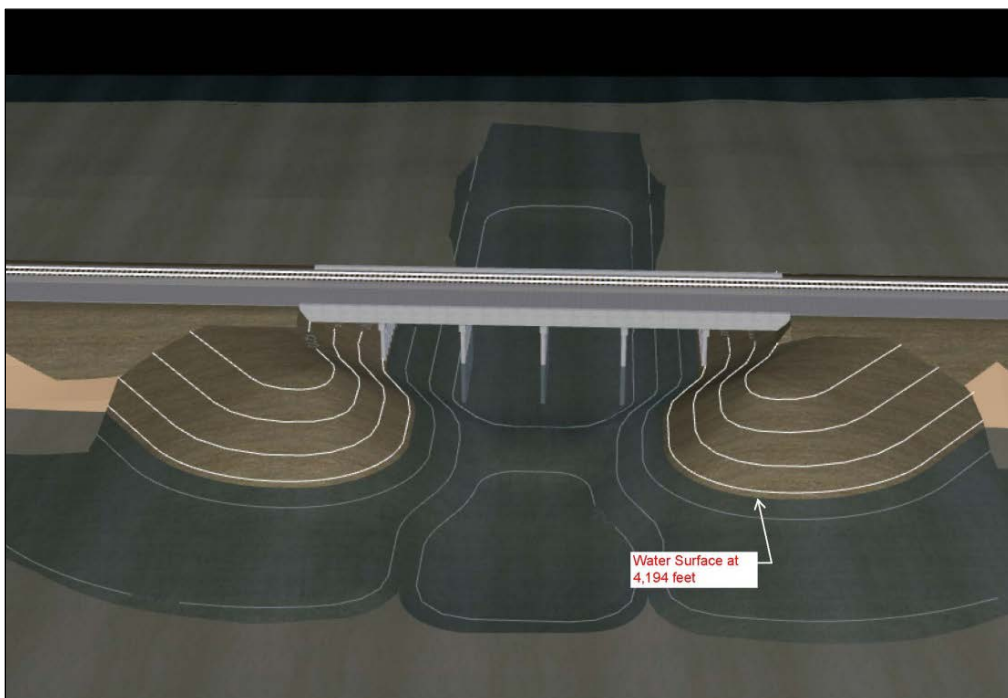

Figure 3-7. Bridge and Causeway Opening (Looking South)



3.13 Long-Term Management Plan

3.13.1 Ownership

UPRR currently owns and operates the causeway across the lake. Because the bridge structure, berm, and opening would be part of the causeway, UPRR would maintain the bridge structure and causeway opening. However, as provided below in Section 3.13.4, Active Long-Term Management Activities, the State would assume responsibility for operation and maintenance of the adjustable features of the causeway opening (control berm and excavated channel outside of the bridge structure) in the future at the point that the State institutes post-permit management activities that modify the causeway opening.

3.13.2 Sustainability

The causeway opening is designed to be self-sustaining; that is, there are no active engineering components (pumps), and the engineered features (structure, control berm, and excavated channel) have been designed to be stable and to require minimum operation and maintenance. The bridge structure's design life is 100 years.

3.13.3 Long-Term Steward

Because the causeway opening would be part of the railroad causeway and infrastructure, it would be protected and maintained in the normal course of railroad operation and maintenance. Therefore, UPRR does not propose to name a third-party long-term steward to manage the mitigation project. UPRR would conduct all long-term maintenance activities associated with the bridge structure and causeway opening after the end of the permit monitoring period in consultation with UDFFSL and state lake managers as needed and consistent with all applicable legal access and regulatory requirements. UPRR would conduct those long-term maintenance activities up until the point that the State of Utah institutes management activities that require modification of the causeway opening. At that point, management and maintenance of the adjustable features of the causeway opening would be as provided in Section 3.13.4 below.

3.13.4 Active Long-Term Management Activities

After the permit monitoring period ends, as approved by USACE and UDWQ, UPRR would continue activities related to the bridge structure, control berm, and causeway opening that facilitate operation of the causeway and maintenance of the causeway opening within 10% of original as-built conditions or as-built conditions resulting from adjustments to the causeway opening pursuant to adaptive management. However, after the permit monitoring period ends, UPRR would not continue long-term lake monitoring and salinity management activities including adjustment of the causeway opening to meet a specified lake salinity goal or objective.

UPRR recognizes that lake managers and stakeholders may wish to conduct lake salinity management activities after the UPRR permit monitoring period ends to achieve a specific North or South Arm salinity or other water quality goal or objective. The adjustable features of the causeway opening may be modified to meet these stated objectives. In such cases, UPRR will coordinate as necessary with USACE, UDWQ, and UDFFSL to allow state managers access to this area and participate in design reviews with the State of Utah to ensure that modifications and construction activities conducted in the causeway opening area do not jeopardize the structural integrity of the causeway or bridge structure and interfere with the operation of the rail line.

UPRR will, in consultation with UDWQ, prepare and propose a Memorandum of Understanding (MOU) to be executed (following a minimum 30-day public notice period provided by UDWQ) before cessation of monitoring is approved as described in Section 3.10.2, Reports and Notifications. The MOU will address, but may not be limited to, the following:

- The parties that will sign the MOU (UPRR, UDWQ, and USACE).
- Coordination to allow UDWQ and its designated agents and contractors access to the control berm and excavated channel area.
- If UDWQ determines that causeway opening modifications are necessary for lake management, the MOU will address determination of the responsible party for all design, construction, and maintenance costs and for complying with all applicable legal and regulatory requirements associated with the modifications and that UPRR will not be financially responsible for control berm modifications by others.
- UPRR participation in design reviews with UDWQ to ensure that design modifications and construction and maintenance activities conducted on the control berm do not jeopardize the structural integrity of the causeway and bridge structure.
- Coordination and observation, by UPRR, during construction activities to ensure the structural integrity of the causeway and bridge structure.
- Determination of post-modification long-term management and monitoring of the causeway opening. Once the site is modified, the entity making the modifications or the state lake manager would assume responsibility for long-term management, monitoring, and maintenance of the control berm.
- After the permit monitoring period and any State modification of the adjustable features of the causeway opening, UPRR will continue to maintain the bridge structure and the causeway to ensure safe rail operations and, if adverse conditions associated with the adjustable features are found, will notify UDWQ.

3.13.5 Funding Mechanism

Because the bridge and associated causeway opening would be part of the causeway, which is a railroad structure, UPRR would self-fund the long-term operation and maintenance of the bridge structure. UPRR would fund long-term operation and maintenance of the causeway opening unless otherwise described in Section 3.13.4, Active Long-Term Management Activities.

3.13.6 Justification for Level of Funding

The level of funding to inspect the bridge and causeway opening is undetermined. UPRR estimates that the cost to conduct these long-term operation and management activities would be funded from UPRR's general causeway operation and maintenance budgets. No additional funding would be required.

3.14 Financial Assurances

UPRR will provide a letter of credit, or some other form of financial assurance acceptable to USACE, to meet permit obligations. The letter of credit will include the following anticipated costs to complete activities required under agency authorizations:

- Right-of-way
- Planning, engineering, and construction for the 180-foot-long bridge structure, associated shoofly construction and demolition, and control berm construction
- Legal fees
- 5-year monitoring and additional data collection
- 5-year maintenance
- 20% contingency costs to cover adaptive management, if required

Funding of long-term maintenance and subsequent modifications of the causeway opening are described in Section 3.13.4, Active Long-Term Management Activities.

3.15 Other Information

No additional information beyond that described in Section 2.0, Water and Salt Balance Modeling and Other Studies Completed by UPRR in Support of the Project, or otherwise referenced in this CMMP, was required by USACE or UDWQ.

4.0 References

- [UDFFSL] Utah Division of Forestry, Fire and State Lands
 2013 Final Great Salt Lake Comprehensive Management Plan and Record of Decision. March 27.
- [UDWQ] Utah Division of Water Quality
 2013 401 Water Quality Certification No. SPK-2011-00755, Temporary Closure of the East Culvert of Great Salt Lake Causeway. December 16.
 2014 Letter to UPRR, subject “Level II Antidegradation Review Comments.” May 9.
 2015 Water Quality Certification No. SPK-2011-00755. Permanent Closure of the East Culvert and Bridge Construction, Great Salt Lake Railroad Causeway. March 2.
- [UGS] Utah Geological Survey
 2012 Great Salt Lake Brine Chemistry Database, 1966–2011.
- [UPRR] Union Pacific Railroad
 2013a Proposed Mitigation and Monitoring Plan, Compensatory Mitigation for Closure of East and West Culverts in the UPRR Causeway over the Great Salt Lake (SPK-2011-00755). January 4.
 2013b Letter to USACE, subject “UPRR – Great Salt Lake Causeway, Culvert Closure and Bridge Construction Report – SPK-2011-00755.” September 25.
 2014a Individual Application, Permanent East Culvert Closure and Bridge Construction Project. January 7.
 2014b Great Salt Lake Causeway Final Water and Salt Balance Modeling Report. April 4.
 2014c Great Salt Lake Causeway Culvert Closure and Bridge Construction Project, Bridge Evaluation Report. June 2.
 2014d Great Salt Lake Causeway Culvert Closure and Bridge Construction Project, Resource Evaluation Report. July 1.
 2015a Compensatory Mitigation and Monitoring Plan. Revised and resubmitted January 7.
 2015b Special Use Lease Agreement Number 30000055. September 17.
- [USACE] United States Army Corps of Engineers
 2012a Regulatory Program Uniform Performance Standards for Compensatory Mitigation Requirements 12505-SPD. August 8.
 2012b Nationwide 14 Permit Verification, UPRR Causeway West Culvert Closure and Bridge Construction, SPK-2011-00755. August 29.
 2013a Letter to Mark McCune, UPRR. Review comments on January 4, 2013, Proposed Compensatory Mitigation and Monitoring Plan. February 14.
 2013b Nationwide 14 Permit Verification, UPRR Causeway Temporary East Culvert Closure and Bridge Construction, SPK-2011-00755. December 6.
 2014 Letter to Mark McCune, UPRR. Transmitting comments in response to public notice project SPK-2011-00755 and additional information request. February 7.
 2015 Individual Permit SPK-2011-00755 for the Permanent Closure of the East Culvert and Bridge Construction, Great Salt Lake. September 7, as amended September 23, 2015, and February 9, 2017.
- [USGS] United States Geological Survey
 No date Watershed Boundary Dataset. water.usgs.gov/GIS/wbd_huc8.pdf. Accessed July 7, 2014.

This page is intentionally blank.

APPENDIX A

U.S. Army Corps of Engineers, Clean Water Act Section 404 Permit (September 7, 2015) as amended September 23, 2015, and February 9, 2017

This amendment included approval
of the Updated Final CMMP



REPLY TO
ATTENTION OF

DEPARTMENT OF THE ARMY
U.S. ARMY CORPS OF ENGINEERS, SACRAMENTO DISTRICT
1325 J STREET
SACRAMENTO CA 95814-2922

September 9, 2015

Regulatory Division (SPK-2011-00755)

Union Pacific Railroad
Attn: Mr. Mark McCune
Director, Structures Design
1400 Douglas Street, Stop 0910
Omaha, Nebraska 68179-0910

Dear Mr. McCune:

We are enclosing your copy of Department of the Army Permit SPK-2011-00755. Please note you are only authorized to complete the work described in the permit.

If you sell the property associated with this permit, the terms and conditions of this permit will continue to be binding on the new owner. To validate the transfer of this permit, have the succeeding party sign the permit transfer section at the end of the permit and forward a copy to this office, along with their printed name, address, telephone number, and other contact information.

The time limit for completing the work is specified in General Condition 1. If the work will not be completed prior to that date, you may request a time extension. Your request for an extension must be received by this office for consideration at least 30 days before the time limit date.

We appreciate your feedback. At your earliest convenience, please tell us how we are doing by completing the Customer Survey from the link on our website at www.spk.usace.army.mil/Missions/Regulatory.aspx.

Please refer to identification number SPK-2011-00755 in any correspondence concerning this project. If you have any questions, please contact Kathleen Anderson at the Utah Regulatory Office, 533 West 2600 South, Suite 150, Bountiful, Utah 84010, by email at Kathleen.Anderson@usace.army.mil, or telephone at 801-295-8380, extension 10.

Sincerely,

A handwritten signature in black ink, appearing to read "Eileen R. Imamura", is written over a horizontal line.

Eileen R. Imamura
Administrative Officer
Regulatory Division

Enclosure



DEPARTMENT OF THE ARMY

U.S. ARMY ENGINEER DISTRICT, SACRAMENTO

CORPS OF ENGINEERS

1325 J STREET

SACRAMENTO CA 95814-2922

REPLY TO
ATTENTION OF

DEPARTMENT OF THE ARMY PERMIT

Permittee: Union Pacific Railroad
Attn: Mark L. McCune, P.E.
Director, Structures Design
1400 Douglas Street, Stop 0910
Omaha, Nebraska 68179-0910

Permit Number: SPK-2011-00755

Issuing Office: U.S. Army Engineer District, Sacramento
Corps of Engineers
1325 "J" Street
Sacramento, California 95814-2922

NOTE: The term "you" and its derivatives, as used in this permit, means the permittee or any future transferee. The term "this office" refers to the appropriate district or division office of the Corps of Engineers having jurisdiction over the permitted activity or the appropriate official of that office acting under the authority of the commanding officer.

You are authorized to perform work in accordance with the terms and conditions specified below. A notice of appeal options is enclosed.

Project Description: To discharge clean rock-fill into approximately 0.86 acre of waters of the United States (waters) to construct a 180-foot-long, pile-supported bridge along the UPRR Causeway across the Great Salt Lake, including an adaptive management control berm structure. The project will replace the aquatic functions of the East and West Culverts from the 1959 section of the Causeway closed due to their failing condition. The 40-foot wide bridge will be constructed with a trapezoidal opening with a bottom elevation (invert) of 4,178 feet. The adaptive management control berm structure will consist of side berms and an invert berm. The control berm's nominal dimensions will be 150 feet wide, with an invert berm at elevation 4,183 feet. The control berm will be constructed as an extension from the north side of the existing Causeway embankment, to effectively create a 150-foot-long bridge. The project will include the excavation of a channel to extend to the north about 150 feet from the invert control berm to meet the lake bottom elevation of 4,183 feet. The excavated channel will extend to the south about 300 feet from the middle of the bridge structure to meet the lake bottom elevation of 4,183 feet. The extended channel will be constructed to a bottom width of about 78 feet. Excavated materials will be removed to an offsite upland disposal location.

UPRR will also discharge temporary fill into approximately 1.28 acres of waters of the U.S. to construct a shoofly to continue rail traffic across the Causeway during construction of the bridge facility. The temporary shoofly rail would be constructed of clean rock riprap obtained from the Lakeside Quarry. The shoofly will be constructed as an extension from the north side of the existing causeway embankment adjacent to the bridge location. Any excess temporary shoofly fill not used to construct the control berm will be removed in its entirety following completion of the project.

Construction of the overall project will result in the discharge permanent fill into a total of 1.03 acres of waters. However, this total includes the discharge of fill into approximately 0.17 acre of waters for closure of the East Culvert. No additional fill will be discharged at the East Culvert location. Retention of the temporary fill discharged in December 2013 to close the failing culvert will be authorized as an administrative action.

All work is to be completed in accordance with the approved January 2015 Final Compensatory Mitigation and Monitoring Plan and attached plans, except as may be modified by the final design plans and construction documents that will be submitted prior to the start of construction.

Project Location: The overall 11.5-mile project corridor is located on the Union Pacific Railroad (UPRR) Causeway across the Great Salt Lake between Milepost 750.5 (East Culvert location) and Milepost 739.1 (approximate west end of temporary shoofly). The project would authorize the permanent closure of the East Culvert as an administrative action; no additional work would be required at this location. The work to construct the bridge structure and control berm would occur near MP 739.78 on UPRR Causeway in the Great Salt Lake in Section 26, Township 6 North, Range 9 West, Salt Lake Meridian, at approximately Latitude 41.221°, Longitude -112.766°, in Box Elder County, Utah.

Permit Conditions:

General Conditions:

1. The time limit for completing the work authorized ends on **December 30, 2016**. If you find that you need more time to complete the authorized activity, submit your request for a time extension to this office for consideration at least one month before the above date is reached.
2. You must maintain the activity authorized by this permit in good condition and in conformance with the terms and conditions of this permit. You are not relieved of this requirement if you abandon the permitted activity, although you may make a good faith transfer to a third party in compliance with General Condition 4 below. Should you wish to cease to maintain the authorized activity or should you desire to abandon it without a good faith transfer, you must obtain a modification of this permit from this office, which may require restoration of the area.
3. If you discover any previously unknown historic or archeological remains while accomplishing the activity authorized by this permit, you must immediately notify this office of what you have found. We will initiate the Federal and state coordination required to determine

if the remains warrant a recovery effort or if the site is eligible for listing in the National Register of Historic Places.

4. If you sell the property associated with this permit, you must obtain the signature of the new owner in the space provided and forward a copy of the permit to this office to validate the transfer of this authorization.
5. If a conditioned water quality certification has been issued for your project, you must comply with the conditions specified in the certification as special conditions to this permit. For your convenience, a copy of the certification is attached if it contains such conditions.
6. You must allow representatives from this office to inspect the authorized activity at any time deemed necessary to ensure that it is being or has been accomplished in accordance with the terms and conditions of your permit.

Special Conditions:

1. Final Compensatory Mitigation and Monitoring Plan (CMMP): You will fully implement the "Proposed Comprehensive Mitigation and Monitoring Plan," dated January 7, 2015, prepared by HDR Engineering, Inc., except as modified by special conditions incorporated below.

- a. When all construction activities are completed and the causeway opening is functioning, the interim monitoring required by the NWP 14 verification issued December 6, 2013, and associated Utah 401 certification, for temporary closure of the East Culvert will conclude.
- b. Following completion of construction of all project activities, you shall submit quarterly and annual monitoring reports for the mitigation project for the duration of the monitoring period, which is a minimum of 5 consecutive years without implementation of adaptive management as outlined in the CMMP.
- c. The monitoring period will reset upon determination by this office that the mitigation is not meeting the salinity performance standards for a project-related cause and resulting adaptive management is implemented in accordance with CMMP Section 3.10.3.
- d. Monitoring will continue until this office has reviewed the Completion Report and determined in writing that the monitoring and adaptive management period can be terminated. This office may extend the monitoring period beyond the minimum 5 consecutive years if we do not approve the Completion Report. If the Completion Report is not approved, this office will provide you with a detailed description of the deficiencies and rationale for extending the monitoring period. In this event you shall meet with this office to consider which aspects of the monitoring and adaptive management program should continue and any other additional terms required for the Completion Report. Unless an alternate time period is approved, you will submit a revised report addressing the identified deficiencies within 60 days of receiving notification that the Completion Report is not approved.

- e. Implementation of the approved mitigation and monitoring plan shall commence no later than July 1, 2015 to minimize the continued effects of reduced circulations of flows between the North and South Arms of the Great Salt Lake as a result of the closure of the East and West Culverts. If implementation of the mitigation is delayed for unavoidable reasons and cannot be completed within 2015, you shall coordinate implementation of a phased plan to complete as much work as possible that could overwinter and facilitate construction of the remainder of the project in 2016. All construction activities shall be completed no later than December 30, 2016.
- f. In accordance with 33 CFR Part 332.7(c) Adaptive Management, you shall notify this office if the compensatory mitigation cannot be constructed in accordance with the approved plan.
- g. The defined salinity performance standards may be revised to address deficiencies in the mitigation project or changes in objectives based on new information and analysis if the new standards will provide for ecological benefits that are comparable or superior to the approved mitigation. These revisions must be approved by the Corps in writing prior to any changes to the performance standards. No other revisions to the performance standards will be allowed except in the case of natural disasters.
- h. To ensure the project is meeting the mitigation objective of duplicating the function of the culverts and resulting in less than minimal adverse effects on aquatic resources, you shall conduct an assessment of effects to aquatic resources (per Section 3.10.3 of the CMMP) when the ambient monitoring results are outside the South Arm salinity performance standard ranges identified in Table 3-7 of the CMMP for four consecutive quarters. Update and re-calibration of the salt balance model shall be conducted concurrently with the aquatic resources assessment to determine whether the changes in salinity outside the performance standard ranges are project caused. You shall submit the results of these analyses within 60 days of the receiving the fourth consecutive quarterly monitoring results that exceed the salinity performance standard ranges. (Note - In accordance with the CMMP, UPRR will initiate the update of the aquatic resource assessment and salt balance model in the event the ambient salinity monitoring results fall outside of the salinity performance standard ranges in Table 3-7 for two consecutive monitoring events. If the fourth quarter monitoring report included at least two consecutive monitoring events with results outside the salinity performance standard ranges, the report shall include the preliminary results of any resource re-assessment analysis for the monitoring events outside the salinity performance standard ranges.)
- i. If this office determines, after reviewing the results of the updated model and the assessment of effect to aquatic resources, that the compensatory mitigation is not duplicating the function of the culverts and is resulting in greater than minimal adverse effects on aquatic resources, we will notify you in writing to proceed with the steps outlined in Section 3.12.2 of the CMMP. The written notification will also notify you whether this office approves the adaptive management measures UPRR

proposed to implement to ensure that the compensatory mitigation is duplicating the function of the culverts and avoiding adverse ecological consequences. Should any adaptive management action require additional permitting from this office through the end of the monitoring period, such action will be authorized as a permit modification.

- j. If, during the monitoring period, new information were to become available that called into question whether more than minimal adverse effects could be resulting to aquatic resources as a result of the project, this office may require you to conduct the analysis in Section 3.10.3.3. and, if necessary, to implement the adaptive management steps outlined in Section 3.12.2, even though the ambient salinity monitoring results may be within performance standards outlined in Table 3-7. This office acknowledges that your resource evaluation assessment and the model-related assumptions for the salinity performance standard ranges are based on the best available scientific information. However, there may be unforeseen future impacts to the aquatic resources of the lake that would make it necessary to determine whether the project is contributing to the cause and effect of observed changes to the lake ecosystem in order to take prudent action to protect aquatic resources. Should such circumstance occur, this office will notify you in writing of the rationale for our determination that it will be necessary to require you to conduct the evaluation set out in Section 3.10.3 of the CMMP.
- k. You shall conduct inspections to ensure compliance with the Causeway Opening Geometry Performance Standards 1, 2 and 4 on a semi-annual schedule for the first two years after completion of the authorized construction activities and on an annual schedule for the remaining monitoring period.
- l. Section 3.13.4, Active Long Term Management Activities. The District Engineer (Corps) should be a signatory to any Memorandum of Understanding for any long-term management activities, as some future management actions would require a Department of the Army permit prior to implementation.
- m. Section 3.14, Financial Assurance. This office waives the requirement to have evidence that the Financial Assurance instrument has been finalized prior to commencement of the authorized activity. The draft final assurance has been reviewed and is approved in general terms, however, some administrative modifications will need to be implemented concerning distribution and/or receipt of the funds prior to its finalization. This office will be named as beneficiary of the instrument. In the event of a default, the funding would be directed by this office to the approved/designated appropriate third-party which will receive the funding through an escrow account. You shall submit the revised financial assurance to this office for review no later than June 15, 2015. You shall submit evidence that financial assurance instrument in the amount of \$5,235,000 has been finalized no later than 45 days after completion of final review and approval by this office.
- n. Milestones for Incremental Release of the Financial Assurance:
 - 1) The defined budget estimate for Planning, Engineering, Mobilization and Construction Costs and those associated with the Right-of-Way Easement may be

released upon Corps concurrence in writing that all activities associated with construction of the bridge and control berm have been completed, including removal of any excess temporary fill not used to construct the control berm.

2) One half-of the budget estimate for contingency and legal funds may be released upon Corps concurrence in writing that all construction activities related to the bridge and control berm structures have been completed.

3) Release of all remaining financial assurance funds (those for monitoring and maintenance activities as well as one-half of the legal fees and contingency funds) may be released upon Corps concurrence in writing that the CMMP has met all performance standards and that the monitoring period has concluded.

2. CONTRACTOR COMPLIANCE: You are responsible for all work authorized herein and ensuring that all contractors and workers are made aware and adhere to the terms and conditions of this permit authorization. You shall ensure that a copy of the permit authorization and associated drawings are available for quick reference at the project site until all construction activities are completed to ensure that the fill work is confined to the authorized footprint to minimize impacts to waters of the U.S.

3. CORPS INSPECTION: With advance notification for scheduling purposes, you and your authorized contractor shall allow representatives from the Corps to inspect the authorized activity at any time deemed necessary to ensure that work is being or has been accomplished in accordance with the terms and conditions of this permit.

4. AS-BUILTS FOR IMPACT: Within 60 days following completion of the authorized work or at the expiration of the construction window of this permit, whichever occurs first, you shall submit as-built drawings and a description of the work conducted on the project site to the Corps for review. The drawings shall be signed and sealed by a registered professional engineer and include the following:

- a. The Department of the Army Permit number.
- b. A plan view drawing of the location of the authorized work footprint (as shown on the permit drawings) with an overlay of the work as constructed in the same scale as the attached permit drawings. The drawing should show all "earth disturbance," and authorized structures. The drawings shall contain, at a minimum, 1-foot topographic contours of the entire site.
- c. Ground and aerial photographs of the completed work. The camera positions and view-angles of the ground photographs shall be identified on a map, aerial photograph, or project drawing.
- d. A description and list of all deviations between the work as authorized by this permit and the work as constructed. Clearly indicate on the as-built drawings the location of any deviations that have been listed.

Further Information:

1. Congressional Authorities: You have been authorized to undertake the activity described above pursuant to:

() Section 10 of the Rivers and Harbors Act of 1899 (33 U.S.C. 403).

(√) Section 404 of the Clean Water Act (33 U.S.C. 1344).

() Section 103 of the Marine Protection, Research and Sanctuaries Act of 1972 (33 U.S.C. 1413).

2. Limits of this authorization.

a. This permit does not obviate the need to obtain other Federal, state, or local authorizations required by law.

b. This permit does not grant any property rights or exclusive privileges.

c. This permit does not authorize any injury to the property or rights of others.

d. This permit does not authorize interference with any existing or proposed Federal projects.

3. Limits of Federal Liability. In issuing this permit, the Federal Government does not assume any liability for the following:

a. Damages to the permitted project or uses thereof as a result of other permitted or unpermitted activities or from natural causes.

b. Damages to the permitted project or uses thereof as a result of current or future activities undertaken by or on behalf of the United States in the public interest.

c. Damages to persons, property, or to other permitted or unpermitted activities or structures caused by the activity authorized by this permit.

d. Design or construction deficiencies associated with the permitted work.

e. Damage claims associated with any future modification, suspension, or revocation of this permit.

4. Reliance on Applicant's Data. The determination of this office that issuance of this permit is not contrary to the public interest was made in reliance on the information you provided.

5. Reevaluation of Permit Decision. This office may reevaluate its decision on this permit at any time the circumstances warrant.

Circumstances that could require a reevaluation include, but are not limited to, the following:

- a. You fail to comply with the terms and conditions of this permit.
- b. The information provided by you in support of your permit application proves to have been false, incomplete, or inaccurate (see 4 above).
- c. Significant new information surfaces which this office did not consider in reaching the original public interest decision.

Such a reevaluation may result in a determination that it is appropriate to use the suspension, modification, and revocation procedures contained in 33 CFR 325.7 or enforcement procedures such as those contained in 33 CFR 326.4 and 326.5. The referenced enforcement procedures provide for the issuance of an administrative order requiring you comply with the terms and conditions of your permit and for the initiation of legal action where appropriate. You will be required to pay for any corrective measures ordered by this office, and if you fail to comply with such directive, this office may in certain situations (such as those specified in 33 CFR 209.170) accomplish the corrective measures by contract or otherwise and bill you for the cost.

6. Extensions. General Condition 1 establishes a time limit for the completion of the activity authorized by this permit. Unless there are circumstances requiring either a prompt completion of the authorized activity or a reevaluation of the public interest decision, the Corps will normally give favorable consideration to a request for an extension of this time limit.

Your signature below, as permittee, indicates that you accept and agree to comply with the terms and conditions of this permit.

Name Mark L. McCune
Title Director, Structures Design
Permittee

2 Sept. 2015
Date

This permit becomes effective when the Federal official, designated to act for the Secretary of the Army, has signed below.

FOR THE COMMANDER:

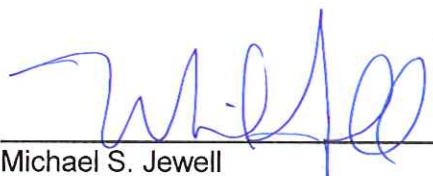
Michael S. Jewell
Chief, Regulatory Division

7 Sep 2015
Date

When the structures or work authorized by this permit are still in existence at the time the property is transferred, the terms and conditions of this permit will continue to be binding on the new owner(s) of the property. To validate the transfer of this permit and the associated liabilities associated with compliance with its terms and conditions, have the transferee sign and date below.

Name _____
Title _____
Transferee

Date



REPLY TO
ATTENTION OF

DEPARTMENT OF THE ARMY
U.S. ARMY CORPS OF ENGINEERS, SACRAMENTO DISTRICT
1325 J STREET
SACRAMENTO CA 95814-2922

September 23, 2015

Regulatory Division (SPK-2011-00755)

Union Pacific Railroad
Attn: Mr. Mark L. McCune, P.E.
Director, Structures Design
1440 Douglas Street, Stop 0910
Omaha, Nebraska 68179-0910

Dear Mr. McCune:

We are responding to your September 2, 2015 letter transmitting two copies of the signed proffered permit and requesting to modify Department of the Army Permit number SPK-2011-00755. The permit was finalized on September 7, 2015. The permit was issued to authorize permanent closure of the East Culvert and construction of the 180-foot-long, pile-supported bridge, with an adaptive management control berm structure, on the Union Pacific Railroad Causeway across the Great Salt Lake. The site for the new bridge is located on the Causeway near Milepost 739.78, Latitude 41.221°, Longitude -112.766°, in Box Elder County, Utah, and can be seen on the UT-LAKESIDE USGS Topographic Quadrangle.

As previously discussed with this office, you requested that we modify and update the deadlines for permit Special Conditions 1.e and 1.m. The deadline dates for these two conditions had passed due to delays in obtaining an access easement from the Utah Division of Forestry Fire and State Lands. Special conditions 1.e and 1.m of Standard Individual Permit Number SPK-2011-00755 are hereby modified as follows:

1.e. Implementation of the approved mitigation and monitoring plan shall commence no later than October 15, 2015 to minimize the continued effects of reduced circulation of flows between the North and South Arms of the Great Salt Lake as a result closure of the East and West Culverts. If implementation of the mitigation is delayed for unavoidable reasons and cannot be completed within 2015, you shall coordinate implementation of a phased plan to complete as much work as possible that could overwinter and facilitate construction of the remainder of the project in 2016. All construction activities shall be completed no later than December 30, 2016.

1.m. Section 3.14, Financial Assurance. This office waives the requirement to have evidence that the Financial Assurance instrument has been finalized prior to commencement of the authorized activity. The draft financial assurance was reviewed and approved in general terms; however, some administrative modifications will need to

be implemented concerning distribution and/or receipt of funds prior to its finalization. This office shall be named as beneficiary of the instrument. In the event of a default, the funding would be directed by this office to the approved/designated appropriate third-party to receive the funding through an escrow account. You shall submit the revised Financial Assurance to this office for review no later than October 1, 2015. You shall submit evidence that the Financial Assurance instrument in the amount of \$5,235,000 has been finalized no later than 45 days after completion of final review and approval by this office.

All other terms and conditions of the permit remain in full force and effect. Failure to comply with the terms and conditions of this authorization may result in the suspension or revocation of your permit.

Please refer to identification number SPK-2011-00755 in any correspondence concerning this project. If you have any questions, please contact Kathleen Anderson at the Utah Regulatory Office, 533 West 2600 South, Suite 150, Bountiful, Utah 84010, by email at *Kathleen.Anderson@usace.army.mil*, or telephone at 801-295-8380, extension10. For more information regarding our program, please visit our website at *www.spk.usace.army.mil/Missions/Regulatory.aspx*.

Sincerely,



Kristine S. Hansen
Acting Chief, Utah-Nevada Branch
Regulatory Division

cc:

Stephen L. Cheney, Union Pacific Railroad (SLCHENEY@up.com)



DEPARTMENT OF THE ARMY
U.S. ARMY CORPS OF ENGINEERS, SACRAMENTO DISTRICT
1325 J STREET
SACRAMENTO CA 95814-2922

February 9, 2017

Regulatory Division (SPK-2011-00755)

Union Pacific Railroad
Attn: Mr. Stephen Cheney
Director, M/W Environmental
1400 Douglas Street, Stop 0910
Omaha, Nebraska 68179-0910

Dear Mr. Cheney:

We are responding to your December 7 and December 31, 2016, requests to modify your Department of the Army Permit Number SPK-2011-00755 (Permit). This Permit was issued on September 5, 2015, and modified on September 23, 2015. The Permit was issued to authorize the permanent closure of the East Culvert and to construct a 180-foot-long pile-supported bridge, with an adaptive management control berm structure, on the Union Pacific Railroad (UPRR) Causeway across the Great Salt Lake, near Milepost 739.78, Latitude 41.221°, in Box Elder County, Utah.

Your December 7, 2016, modification request provided a final Revised Table 2 temporary and permanent fill for the project elements and acreage of fill to be placed below the Ordinary High Watermark (OHWM), and requested authorization to make permanent the temporary placement 0.27 acre of fill material discharged in May 2016 for the north causeway staging area. Your stated purpose for retaining the 0.27 acre of fill placed for the north staging area/access road is to provide a slight permanent widening of the north Causeway access road in the area immediately west of the bridge opening for implementation of the monitoring program, for staging that would be needed to facilitate future maintenance and repair, as well as for implementation of any causeway opening adjustments during the mitigation monitoring period or any long-term future management activities.

Permit number SPK-2011-00755 is hereby modified as follows:

Updated Project Description effective December 2016: The permanent discharge of clean rock-fill into approximately 1.13 acres of waters of the United States (waters) is authorized to construct a 180-foot-pile supported bridge along the UPRR Causeway, construction of the adaptive management control berm and excavated channel, and construction of the north staging/access road located immediately west of the Causeway opening. The project will replace the aquatic functions of the East and West Culverts from the 1959 section of the Causeway previously closed due to their failing condition. In addition to the authorization to discharge permanent fill into 1.13 acres of waters to construct the bridge project, the permanent retention of 0.17 acre of fill discharged in December 2013 to close the failing East Culvert is authorized herein as an administrative action. This

administrative action does not authorize the discharge of any additional fill at the East Culvert location.

The 40-foot-wide bridge will be constructed with a trapezoidal opening with a bottom elevation (invert) of 4,178 feet. The adaptive management control berm's nominal dimensions will be 150 feet wide, with an invert berm at elevation 4,183 feet. The control berm will be constructed as an extension of the north side of the existing Causeway embankment, to effectively create a 150-foot-long bridge. The project will include the excavation of a channel to extend to the north about 150 feet from the invert control berm to meet the lake bottom elevation of 4,183 feet. The excavated channel will extend from the south about 300 feet from the middle of the bridge structure to meet the lake bottom elevation of 4,183 feet. The extended channel will be constructed to a bottom width of 78 feet. All excavated materials will be removed to an offsite upland disposal location.

The temporary discharge of clean rock-fill into up to 1.28 acres of waters the U.S. is authorized to facilitate construction of the GSL Causeway bridge project. All temporary fills to include those placed to construct the south temporary access road, the south extension berm, and north berm will be removed in their entirety upon completion of construction activities.

All work is to be completed in accordance with the updated May 2016, *Final Compensatory Mitigation and Monitoring Plan*, and the attached updated final design plans, including the July 27 and August 4, 2015 Control Berm Figures CD01 to CD07; the November 5, 2015, *Pad Extension Layout Plan*; the March 17, 2016, *North Temporary Fill Layout Plan*; the December 7, 2016 Revised Table 2, *Project Elements and Acreage of Fill to be placed below the OHWM*; and the November 7, 2016, *North Side Proposed Fill Plan* for the permanently widened 800 foot long area of the Causeway just west of the bridge opening, which will continue to serve as the north staging/access road.

Special Conditions:

1. **Final Compensatory Mitigation and Monitoring Plan (CMMP):** Except as modified by the special conditions incorporated below, you will fully implement the updated Comprehensive Mitigation and Monitoring Plan, dated May 2016, including any minor amendments/modifications or the addition of final Appendices that may occur after the date of this Permit modification:

a.-k. No changes.

I. Section 3.13.4, **Active Long-Term Management Activities:** The U.S. Corps of Engineers (the Regulatory Division Chief or his designee) shall be a signatory to the Memorandum of Understanding to be executed between the Union Pacific Railroad and the Utah Department of Environmental Quality (Division of Water Quality) prior to cessation of the mitigation monitoring. A Section 404 permit may be required prior to implementation of any post-monitoring long-term management activities that would employ the adjustable control berm.

m. Section 3.14, **Financial Assurance**. This office waives the requirement to have evidence that the Financial Assurance instrument has been finalized prior to commencement of the authorized activity. The draft final assurance instrument has been reviewed and your proposed form of escrow agreement and the proposed escrow agent are approved to satisfy your financial assurance obligations under this Permit. Should the financial assurances be terminated prior to Corps issuance of a Notice of Default or written concurrence that implementation of the CMMP has met all performance standards and the monitoring period has concluded, you shall provide a substitute financial assurances acceptable to the Corps within 30 days of termination.

1) This office has received your notification that construction of the 180-foot-long bridge, invert berm, control berm and excavated channel has been completed, including the removal of any excess temporary fill not used to construct the control berm. A Special Use Lease has been completed to ensure your access to the bridge and control berm on the Great Salt Lake Causeway. Therefore, the required financial assurance instrument shall cover the following remaining items from your updated October 1, 2015 budget estimate: one-half legal fees, one-half adaptive management contingency, which includes sufficient funds to cover at least one adjustment of the control berm should that become necessary pursuant to CMMP Section 3.12, and monitoring and maintenance costs, for a total of \$1,120,000.

2) In the event of a default, this office would notify you that you must propose for Corps approval, within 30 days, an appropriate third-party that will be designated to carry out the remaining obligations under the Permit and CMMP. Upon approval of your proposal of the designated third-party, this office will provide the escrow agent with a copy of the Corps approval of the designated third-party and will notify the escrow agent of the default, which triggers the escrow agent's disbursement of the funds in the escrow account to the designated third-party.

3) No later than 30 days from the date of this Permit modification, you shall submit evidence to this office that the approved financial assurance instrument has been executed and that the escrow account in the amount of \$1,120,000 has been established.

n. **Milestones for Release of the Financial Assurance**: All remaining financial assurance funds held in the approved escrow account (those for monitoring and maintenance activities as well as one-half of the legal fees and contingency funds) may be released upon Corps concurrence in writing that implementation of the CMMP has met all performance standards and that the monitoring period has concluded.

All other terms and conditions of the permit remain in full force and effect. Failure to comply with the terms and conditions of this authorization may result in the suspension or revocation of your Permit.

In addition to the administrative action described above that authorizes permanent retention of the 0.17 acre of fill placed to close the East Culvert, this Permit modification serves as formal notification to UPRR that the August 2012 Nationwide Permit 14 (NWP 14) verification for the West Culvert has been reinstated. Based on review of our file, we determined that all issues related to the 2013 NWP suspension were resolved, therefore, our

administrative records should include written notice that you are in compliance with all terms and conditions of the NWP 14 verifications issued for closure of the East and West Culverts.

Please refer to identification number SPK-2011-00755 in any correspondence concerning this project. If you have any questions, please contact Kathleen Anderson at the Utah-Nevada Regulatory Branch, 533 West 2600 South, Suite 150, Bountiful, Utah 84010, by email at Kathleen.Anderson@usace.army.mil, or telephone at (801) 295-8380, extension 10. For more information regarding our program, please visit our website at www.spk.usace.army.mil/Missions/Regulatory.aspx.

Sincerely,

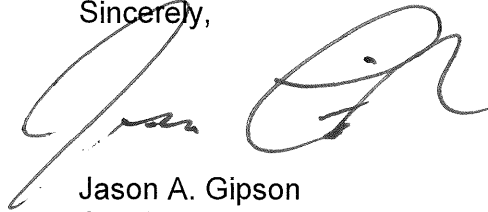
A handwritten signature in black ink, appearing to read "Jason A. Gipson". The signature is fluid and cursive, with a large initial "J" and "G".

Jason A. Gipson
Chief, Utah-Nevada Branch
Regulatory Division

Enclosures

cc:

William Damery, Utah Division of Water Quality (wdamery@utah.gov)

APPENDIX B

**Utah Division of Water Quality,
401 Water Quality Certification (March 2, 2015)**



State of Utah

GARY R. HERBERT
Governor

SPENCER J. COX
Lieutenant Governor

Department of
Environmental Quality

Amanda Smith
Executive Director

DIVISION OF WATER QUALITY
Walter L. Baker, P.E.
Director

MAR 02 2015

Mark McCune, P.E.
Director, Structure Design
Union Pacific Railroad
1400 Douglas Street, Stop 0910
Omaha, Nebraska
68179-0910

Subject: Approval 401 Water Quality Certification with Conditions.
Water Quality Certification No.: SPK 2011-00755 March 2, 2015.
USACE 404 Permit No.: SPK 2011-0755 (to be determined in 2015).

Applicant: Union Pacific Railroad (UPRR).

Project: "Permanent East Culvert Closure and Bridge Construction, Great Salt Lake Railroad Causeway" Utah Water Quality 401 Certification Application dated January 7, 2014 which is also known as the USACE Clean Water Act Section 404 permit entitled "Permanent East Culvert Closure and Bridge Construction, Union Pacific Causeway, Great Salt Lake Utah."

Purpose: To duplicate, as closely as possible, the aquatic function (water and salt transfer) lost due to the closure of the East and West Culverts by constructing a new causeway opening. The new causeway opening will be a bridge that is 180 feet long and an earthen control berm at elevation 4,183 feet that creates an opening 150 feet long.

Location: The East Culvert was located at UPRR Mile Post 750.53, latitude 41.221 N. and longitude 112.561 W., Box Elder County, Utah. The West Culvert was located at UPRR Mile Post 744.94, latitude 41.223 N. and longitude 112.668 W., Box Elder County, Utah. The new causeway opening will be located at UPRR Mile Post 739.78, latitude 41.221 N. and 112.766 W., Box Elder County, Utah. The locations of the bridge opening, East Culvert, and West Culvert locations can be viewed on USGS Quadrangles: Lakeside, Carrington Island NE, and Carrington NW, respectively.

Watercourse: Great Salt Lake, Box Elder County, Utah.

Public Comment Period: 01/21/2015 – 2/20/2015.

Dear Mr. McCune:

Pursuant to Section 401 of the Federal Water Pollution Control Act, commonly known as the Clean Water Act (CWA), the Utah Department of Environmental Quality, Division of Water Quality (DWQ) certifies that the Union Pacific Railroad (UPRR) has provided reasonable assurances that any discharge associated with the permanent closure of the East Culvert of the Great Salt Lake Causeway will not violate surface water quality standards, or cause additional degradation in surface waters not presently meeting water quality standards. All conditions from the 401 Water Quality Certification SPK 2011-00755

dated December 16, 2013 are incorporated by reference and are enforceable under this Certification. In accordance with Section 401(a)(1) of the CWA [33 U.S.C. Sec. 1341(a)(1)], DWQ hereby issues this Water Quality Certification provided the conditions outlined below are met and included in the U.S. Army Corps of Engineers (USACE) 404 standard individual permit SPK-2011-00755 (to be determined in 2015) if issued to the Union Pacific Railroad.

The affected portions of Great Salt Lake have the following beneficial uses Utah Administrative Code (UAC R317-2-6):

Class 5A - Gilbert Bay: Protected for frequent primary and secondary contact recreation, waterfowl, shore birds and other water-oriented wildlife including their necessary food chain, and

Class 5B - Gunnison Bay: Protected for infrequent primary and secondary contact recreation, waterfowl, shore birds and other water-oriented wildlife including their necessary food chain.

As documented in Utah's *Draft 2014 Integrated Report*, Great Salt Lake was assessed as Category 3. Category 3 means that insufficient data and information are available to determine whether the uses are supported by the water quality. With the exception of a single numeric criterion for selenium for Gilbert Bay, no other numeric water quality criteria are available for Gilbert and Gunnison Bays. Gilbert and Gunnison Bays continue to be protected by Utah's Narrative Standards (UAC R317-2-7.2) and antidegradation policy (UAC R317-2-3).

The USACE is requested to include all of the conditions of this 401 Water Quality Certification (Certification) in the USACE 404 Individual Permit SPK-2011-00755 (to be determined in 2015) and issued to the Union Pacific Railroad (UPRR).

Approval is hereby given to permanently close the East Culvert of the UPRR Causeway in the Great Salt Lake under the following conditions.

1. The installation of the Bridge and Control Berm will be completed as outlined in Section 3.7.1 and Appendix A of the January 2015 Proposed Compensatory Mitigation and Monitoring Plan (CMMP) by December 31, 2016, unless the action is prevented or delayed by a force majeure or by a delay in approval by DWQ or USACE. In the event that the bridge and control berm construction is delayed beyond Dec 31, 2016 due to UPRR's failure, the Director may take appropriate action to ensure completion.
2. UPRR shall allow the Director, or authorized representatives, upon the presentation of credentials and other documents as may be required by law, and in compliance with all UPRR and legal safety requirements to:
 - A. enter upon the UPRR Causeway where a regulated facility or activity is located or conducted, or where records must be kept under the conditions of the Certification;
 - B. have access to and copy, at reasonable times, any records that must be kept under the conditions of this Certification;
 - C. inspect at reasonable times any facilities, equipment (including monitoring and control equipment), practices, or operation regulated or required under this Certification;
 - D. sample or monitor at reasonable times, for the purpose of assuring Certification compliance or as otherwise authorized by the Utah Water Quality Act, any substances or parameters at any location; and
 - E. conduct activities contemplated in the CMMP, as negotiated in the Long-Term Memorandum of Understanding (MOU) (see condition 3.E. below);
 - F. inspections during the bridge implementation phase will be at Director's discretion in coordination with UPRR.
3. UPRR must adhere to all elements defined in the CMMP, unless otherwise approved by the Director, including these clarifications and modifications:

- A. Fulfill the Water Quality (Salinity and Salt Balance) Performance Standard as described in January 2015 CMMP, Section 3.9.2, Table 3-7 and defined by the ranges shown in the table below.

South Arm Water Surface Elevation Range (feet above mean sea level))	Salinity Performance Standard Range (Percent Salinity)
4,193 up to 4,195	11.9 – 26.3
4,195 up to 4,197	9.9 – 25.0
4,197 up to 4,199	8.8 – 22.7
4,199 up to 4,201	7.6 – 20.5
4,201 up to 4,203	6.7– 18.5
4,203 up to 4,205	6.3 – 16.5
4,205 up to 4,207	6.2 – 14.7
4,207 up to 4,209	6.3 – 13.1
4,209 up to 4,211	6.7 – 11.5

1. If the Great Salt Lake water surface elevation falls below or above the historic elevation range used to develop the Performance Standards (South Arm Water Surface Elevation <4,193 or >4,211) for two consecutive quarters or after 1 quarter when the salinity from the previous quarter was outside of the Salinity Performance Standard Ranges, UPRR shall update and extend the 2012 UPRR/USGS Model after second consecutive quarter using the same methodology used to derive the original Salinity Performance Standard Ranges (salinity ranges) in order to calculate a salinity range at the new elevation within 90 days of the determination. In addition, UPRR may submit alternative methodology(s) to determine the appropriate salinity range such as extrapolation of the Salinity Performance Standard Ranges if the Director concurs.

- B. Compliance with the Salinity Performance Standard Ranges described in Condition 3.A. will be documented through quarterly data and annual reports required by Condition 3.G. In addition, the following steps shall be followed to ensure that if the Salinity Performance Standard Ranges are not being met, adaptive management will be implemented to resolve the deviations:

1. When ambient monitoring results for salinity are outside the Performance Standard Ranges for 4 consecutive quarters, UPRR will complete the process as described in the January 2015 CMMP, Section 3.10. 3. UPRR will then submit to DWQ a proposed remediation plan to meet the Salinity Performance Standard Ranges within 2 months of the 4th consecutive quarter results, unless UPRR demonstrates and the Director concurs that Condition 3.B.1.a. applies, or if Condition 3.B.1.a. does not apply but Condition 3.B.1.b. does apply. UPRR will implement adaptive management within 2 months of receiving the Director’s approval of the remediation plan. The provision to hold a public notice and comment period on any remediation plans to implement adaptive management (as described in the January 2015 CMMP, Section 3.12.2) will be at the Director’s discretion.

a. The deviations from the Salinity Performance Standard Ranges are not project caused and the bridge replicates the function of the free-flowing culverts. This determination will be based on a comparison of quarterly salinity values from the observations and from a model simulation that replaces the bridge with the free-flowing culverts utilizing the updated 2012 UPRR/USGS Model. The difference in salinity between the bridge and the free-flowing culverts will be calculated for each quarter and averaged. An average difference in salinities of no more than 2% absolute

difference or 10% relative difference, whichever is less, will be considered to support the determination that the observed deviations of salinity from the Salinity Performance Standard Ranges are not project-caused.

b. The beneficial uses are and will be protected under the new salinity regime.

- C. The 2012 UPRR/USGS Model (Model) update required in Condition 3. B. shall follow the January 2015 CMMP, Section 3.10.3 including the following additional tasks:
1. Verify the equations used in the Model to simulate bi-directional water and salt transfer through the openings in the causeway utilizing available monitoring data, if appropriate and feasible, or conduct sensitivity analysis;
 2. Review methods and results from latest GSL modeling efforts, including Division of Forestry, Fire, State Lands (FFSL) Great Salt Lake (GSL) Integrated Water Resources Model, and incorporate improvements into the Model if consistent and appropriate within the regulatory framework;
 3. Report the results of 2012UPRR/USGS Model update to DWQ no later than 2 months from the fourth quarter water quality monitoring report.
- D. UPRR will conduct the required monitoring until the results demonstrate that the Salinity Performance Standard Ranges are being met and trends indicate they will continue to be met into the future. UPRR may request cessation of monitoring and adaptive management by submitting a Completion Report that includes no less than 5 years of monitoring results after the most recent causeway modification affecting water and salt transfer. If after 60 days of public notice the director concurs that the Salinity Performance Standard Ranges are met, the Director will approve cessation of monitoring and adaptive management. The Completion Report will document the results of the monitoring during the agreed permit monitoring period after the bridge and berm completion and describe any long-term changes in flow and salt transfer associated with the project in relation to lake salinity and the beneficial uses of the Great Salt Lake, mitigation objectives, anti-degradation policy, numeric criteria and narrative standards. If the Completion Report is not approved, the Director will provide UPRR with a detailed description of the deficiencies and UPRR will submit a revised report addressing these deficiencies within 60 days of receiving notification, unless an alternative time period is approved by the Director. UPRR, and DWQ shall meet and consider which aspects of the monitoring and adaptive management program should continue and any other additional terms required for the Completion Report.
- E. A Long-Term Management Memorandum of Understanding (MOU) will be drafted that defines the DWQ's, UPRR's and the Utah Department of Natural Resource's legal, financial and regulatory role relating to the modifications of and access to the control berm and causeway opening after the UPRR monitoring period ends. The relevant parties and their roles must be defined and the MOU signed prior to the Director granting cessation of the monitoring period and the relinquishing of adaptive management responsibility as defined in the January 2015 CMMP, Section 3.10.2 and Condition 3d. The proposed MOU must be public noticed for a minimum of 30 days.
- F. Determination of compliance with the Causeway Opening Geometry Performance Standards 1, 2 and 4 of the January 2015 CMMP will be made semi-annually for the first two years after bridge completion and then annually until cessation of monitoring is granted by the Director. Triggers for adaptive management will be based on the semi-annual and annual measurement results with the targets noted in the section entitled *Causeway Opening Geometry Performance Standards* of the January 2015 CMMP, Section 3.9.1, Table 3-5.

- G. Quarterly water quality data monitoring reports to document compliance with the Performance Standards referenced in January 2015 CMMP, Section 3.9.2, Table 3-7 will be submitted to the DWQ within 45 days of a sampling event or as otherwise approved by the Director. The annual report shall be submitted by February 1 of each year following the reporting period. All annual reports will be approved by the Director in writing. If the annual report is not approved, the Director will provide UPRR with a detailed description of the deficiencies and UPRR will submit a revised report addressing these deficiencies within 60 days of receiving notification, unless an alternative time period is approved by the Director.
 - H. The January 2015 CMMP must be updated with the conditions outlined in this 401 Water Quality Certification and submitted to the Director for approval. UPRR will complete this update to the Director no more than 30 days from the issuance of the related USACE 404 Permit No.: SPK 2011-0755. If the revised CMMP is not approved, the Director will provide UPRR with a detailed description of the deficiencies and UPRR will submit a revised CMMP addressing these deficiencies within 60 days of receiving notification, unless an alternative time period is approved by the Director.
 - I. Submittal of a revised Quality Assurance Project Plan (QAPP) and Sampling and Analysis Plan (SAP) will be within 120 days of receiving the Director's approval of the Final CMMP. The QAPP must meet all EPA Requirements for Quality Assurance Project Plans (EPA/240/B-001/003).
4. During construction of the bridge and earthen berms, Best Management Practices (BMPs) are required to minimize the erosion-sediment load to adjacent waters during project construction activities. Sediment retention efforts will be put in place at all drainage areas along the construction corridor to minimize movement of sediment into the water courses. Failure to implement appropriate BMPs may result in a Notice of Violation of the Utah Water Quality Act.
 5. Utah Code Annotated 19-5-114 requires that any spill or discharge of oil or other substances which may cause pollution to the waters of the State, including wetlands, must be immediately reported to the Utah DEQ Spill Hotline at (801) 536-4123, a 24-hour phone number. UPRR agrees to fully remediate any spill or discharge in accordance with all applicable regulations.
 6. UPRR shall not use any fill material which may leach organic chemicals (e.g., discarded asphalt) or nutrients (e.g., phosphate rock) into Great Salt Lake.
 - o The applicant shall obtain the following permits from DWQ prior to the construction phase of the project: Dewatering activities, if necessary during the construction, may require coverage under the UPDES General Permit for Construction Dewatering, Permit No. UTG070000. A fact sheet describing the permit application procedures are located on our web site at: <https://secure.utah.gov/stormwater/main.html>. The permit requires water quality monitoring every two weeks to ensure that the pumped water is meeting permit effluent limitations, unless the water is managed on the construction site.
 - o Construction activities that disturb one acre or more are required to obtain coverage under the Utah Pollutant Discharge Elimination System (UPDES) Storm Water General Permit for Construction Activities, Permit No. UTR300000. The permit requires the development of a storm water pollution prevention plan (SWPPP) to be implemented and updated from the commencement of any soil disturbing activities at the site until final stabilization of the project. A fact sheet describing the permit application procedures are located on our web site at: <https://secure.utah.gov/stormwater/main.html>.
 7. UPRR must acquire all necessary easements, access authorizations and permits to ensure they are able to build the bridge. Meeting this requirement will fulfill the easement requirement stated in condition #4 of 401 Water Quality Certification SPK 2011-00755 dated December 16, 2013.

Page 6

Please contact Mr. Bill Damery at (801) 536-4354, wdamery@utah.gov with any questions you may have concerning this 401 Water Quality Certification with Conditions.

Sincerely,

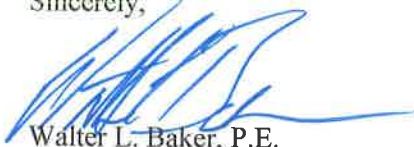

Walter L. Baker, P.E.
Director.

WLB:WD:mc

cc: Kathleen Anderson, USACE.
Julia McCarthy, USEPA.

File: SPK 2011-00755 March 2, 2015.

APPENDIX C

UDWQ Approval of Updated Final CMMP
(June 16, 2017)



State of Utah

GARY R. HERBERT
Governor

SPENCER J. COX
Lieutenant Governor

Department of
Environmental Quality

Alan Matheson
Executive Director

DIVISION OF WATER QUALITY

JUN 16 2017

Stephen L. Cheney
General Director M/W – Environmental
Union Pacific Railroad
1400 Douglas St., Stop 0910
Omaha, NE 68179

Dear Mr. Cheney,

The purpose of this letter is to convey the Utah Division of Water Quality Director's (Director) approval on several items relating to the Union Pacific Railroad East Culvert Closure and Bridge Construction Project (Project) and the associated SPK 2011-0755 (Cert), both Temporary Closure (dated Dec 16, 2103) and Permanent Closure (dated March 2, 2015).

Related to the Project Cert dated March 2, 2105 the Director approves the following items.

- 1) Updated final *Compensatory Mitigation and Monitoring Plan (CMMP)* dated May 25, 2016. DWQ has determined that it is protective of water quality and consistent with the requirements of the March 2, 2015 401 Water Quality Certification SPK 2011-00755 including Condition 3H. This approval was based on several iterative revisions including the most recent CMMP revision submitted on January 12, 2017.
- 2) Replacement of the original CMMP dated January 7, 2015 with the updated and final CMMP dated May 25, 2016, which was referred to in several Cert conditions.
- 3) Replacement of Certification sub-conditions 3A, 3B, 3C1 and 3C2 with language found in CMMP Sections 3.9.2 and 3.10.3. This decision was based in part on 1) it will be protective of surface water quality standards of the Great Salt Lake and 2) is a product of extensive negotiations in the settlement of UPRR's Request for Agency Action dated April 1, 2015.
- 4) Final Sampling and Analysis Plan, dated October 25, 2016.

195 North 1950 West • Salt Lake City, UT
Mailing Address: P.O. Box 144870 • Salt Lake City, UT 84114-4870
Telephone (801) 536-4300 • Fax (801) 536-4301 • T.D.D. (801) 536-4284

www.deq.utah.gov

Printed on 100% recycled paper

Related to the Project Certification dated Dec. 16, 2013 the Director approves the following:

- 1) All Certification conditions being satisfied upon successful completion of the compensatory mitigation bridge construction, as documented in Union Pacific Railroad's notification letter dated December 30, 2016.
- 2) The revised construction schedule request submitted on Oct. 31, 2016 to delay the new causeway breach until Dec. 1, 2016.

Please contact Bill Damery at (801) 536-4354 or email wdamery@utah.gov with any questions you may have concerning these approvals.

Regards,



Erica Brown Gaddis, PhD
Acting Director

EBG/WBD/blj

cc: Kathleen Anderson, United States Army Corp of Engineers, via email
Julia McCarthy, United States Environmental Protection Agency, via email

DWQ-2017-004365

APPENDIX D

Final Bridge and Control Berm Design Plans

Color table: \\omtr-sr-1\EGG\CADStandards\UPRR\TRTables\UPRR.tbl
 \\omtr-sr-1\EGG\CADStandards\UPRR\TRTables\UPRR.tbl
 pw:/06/818/00000000005625/Lakeside_740_CD01.dgn
 8/4/2015 10:58:05 AM

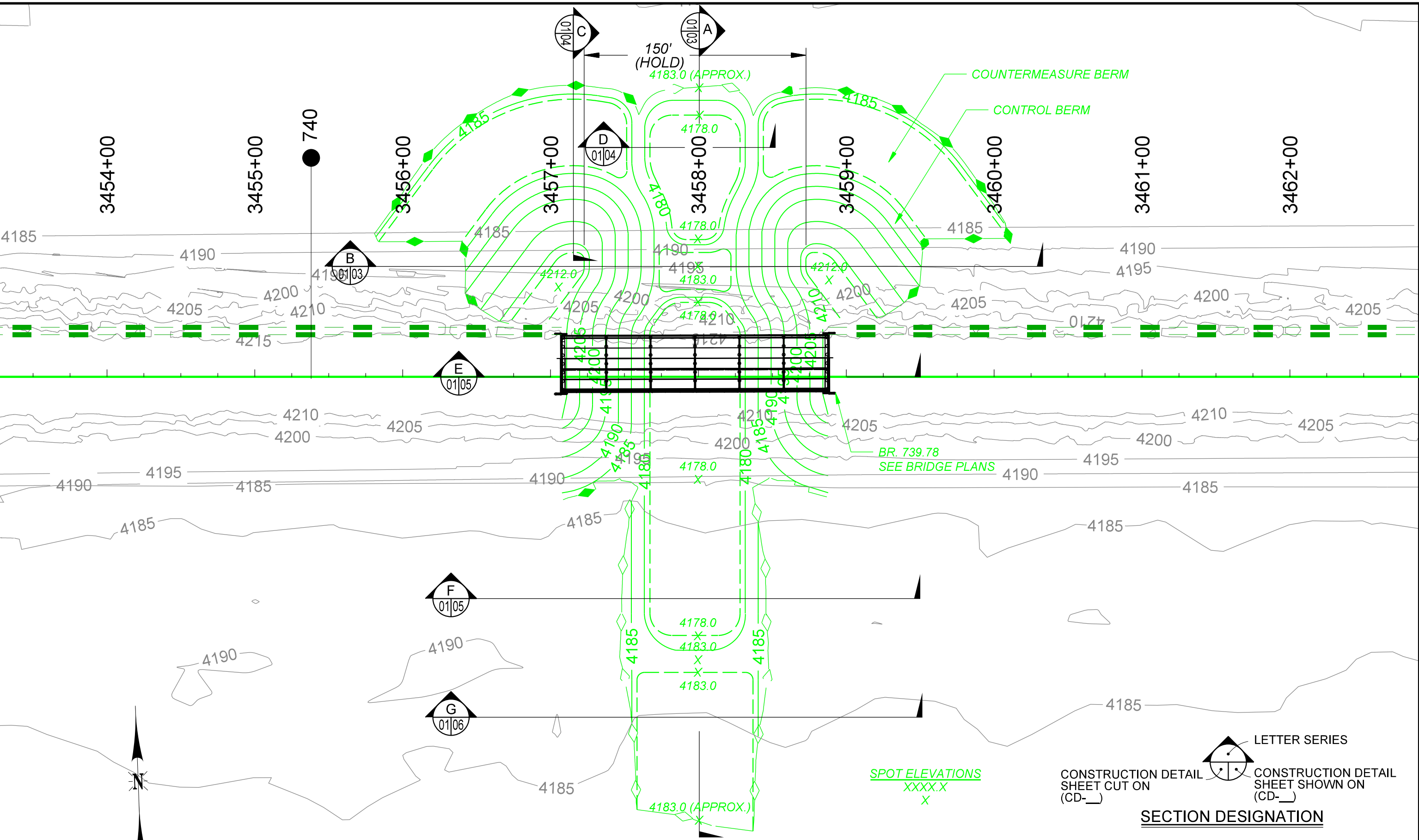

NOTE:
 FOR SECTIONS A THRU G, SEE
 SHEETS CD03 THRU CD06.

SPOT ELEVATIONS
 XXXX.X
 X

CONSTRUCTION DETAIL SHEET CUT ON (CD-)

LETTER SERIES

CONSTRUCTION DETAIL SHEET SHOWN ON (CD-)

SECTION DESIGNATION



HR		<small>DRAWN BY:</small> BND	UNION PACIFIC RAILROAD	<small>Office of Assistant Vice President Engineering Design</small>
		<small>CHECKED BY:</small> ADK	LOCATION:	LAKESIDE SUBDIVISION - BR. 739.78
		<small>DATE:</small> 4 AUG 2015	<small>DWG TITLE:</small>	CONTROL BERM GENERAL PLAN
		<small>SHEET NUMBER:</small> CD01 of CD07		

Color tables: \\omtrtr-v1\EGGCADStandards\UPRR\TR\Tables\UPRR.tbl
 \\omtrtr-v1\EGGCADStandards\UPRR\TR\HQR\PLTDRY\vb1\HQR-UPRR_VB1_pentable.tbl
 pw:/008180/000000000005625/Lakeside_740_CD02.dgn
 8/4/2015 10:59:08 AM

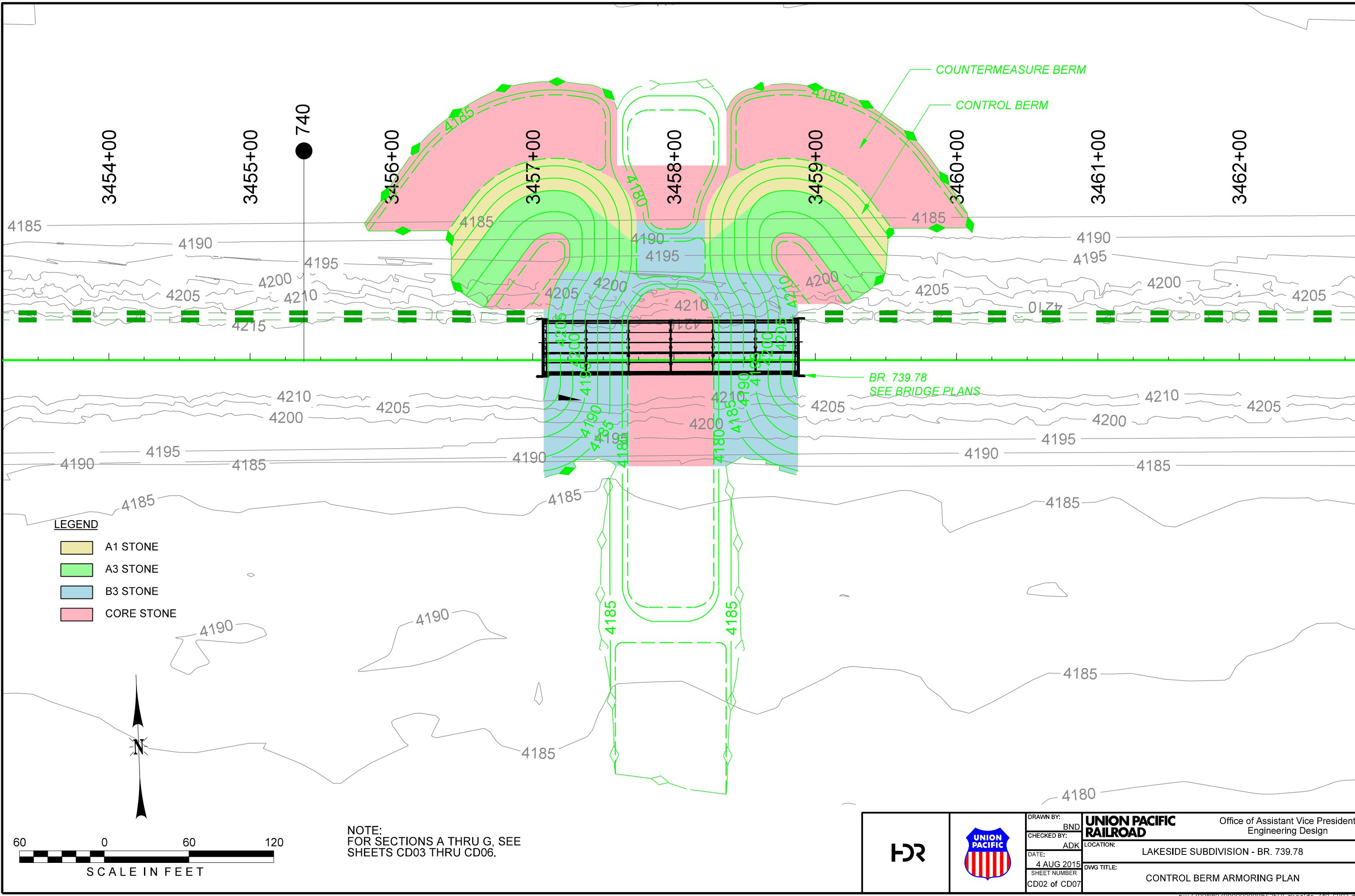

LEGEND

- A1 STONE
- A3 STONE
- B3 STONE
- CORE STONE



NOTE:
 FOR SECTIONS A THRU G, SEE
 SHEETS CD03 THRU CD06.

		DRAWN BY: BND	UNION PACIFIC RAILROAD Office of Assistant Vice President Engineering Design
		CHECKED BY: ADK	LOCATION: LAKESIDE SUBDIVISION - BR. 739.78
		DATE: 4 AUG 2015	DWG TITLE: CONTROL BERM ARMORING PLAN
		SHEET NUMBER CD02 of CD07	

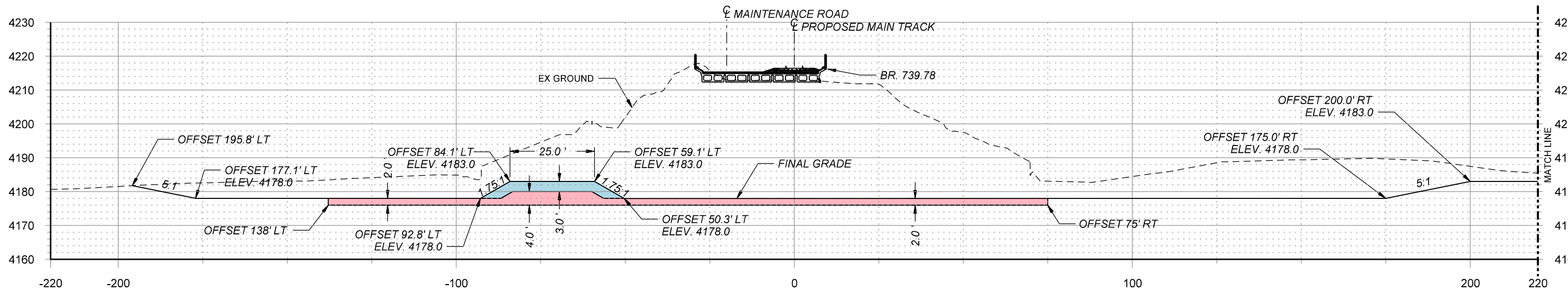

LEGEND

- A1 STONE
- A3 STONE
- B3 STONE
- CORE STONE

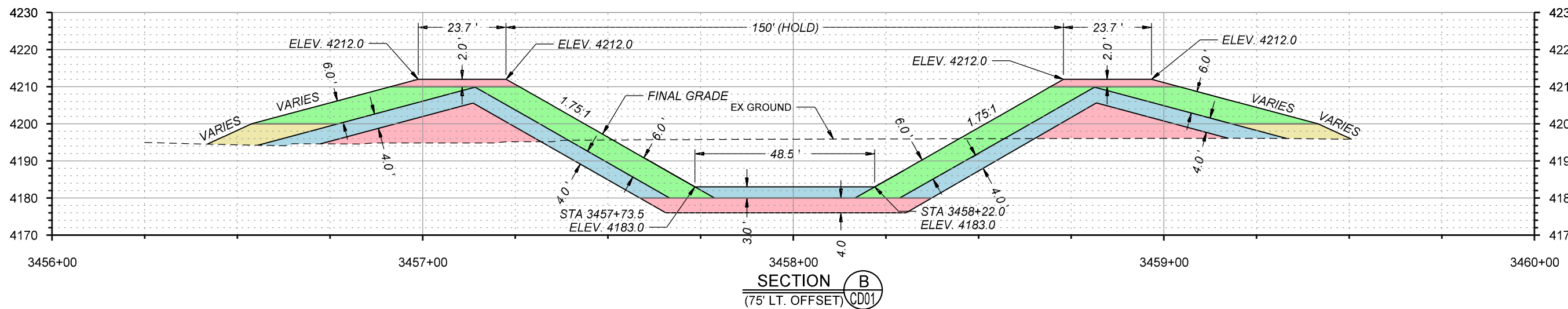
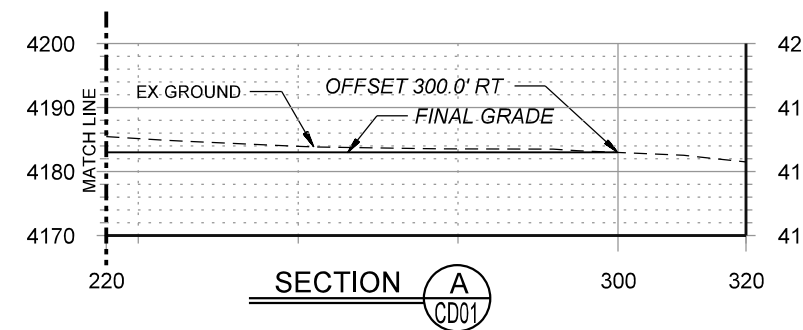

NOTE:
FOR PLAN VIEW OF SECTIONS,
SEE SHEET CD01.



DRAWN BY: BND
CHECKED BY: ADK
DATE: 27 JULY 2015
SHEET NUMBER
CD03 of CD07

UNION PACIFIC RAILROAD
Office of Assistant Vice President
Engineering Design
LOCATION: LAKESIDE SUBDIVISION - BR. 739.78
DWG TITLE: CONTROL BERM EXCAVATION SECTIONS

Color table: \\omtr-srv1\EGCADStandards\UPRR\TR\Tables\UPRR.tbl
 \\omtr-srv1\EGCADStandards\UPRR\TR\HDR\PLTDRY\vb1\HDR-UPRR-VB1.pentable.tbl
 p:\77\08180\0000000000\56251\Lakeside_740_CD03.dgn
 7/27/2015 3:56:56 PM

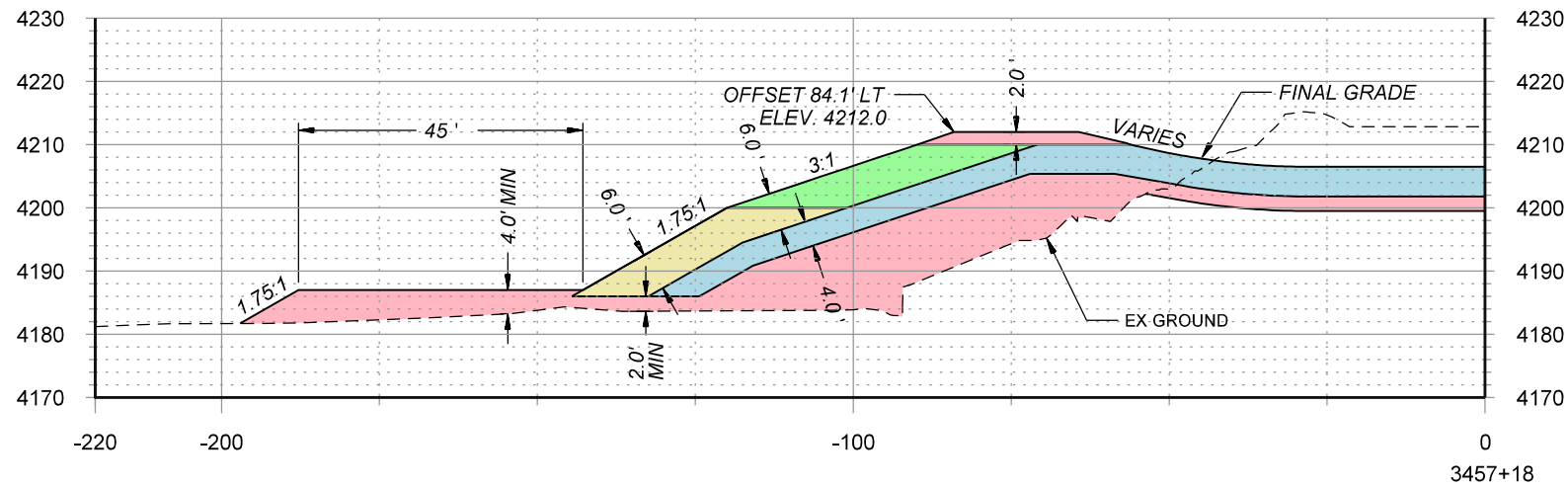

- LEGEND**
- A1 STONE
 - A3 STONE
 - B3 STONE
 - CORE STONE

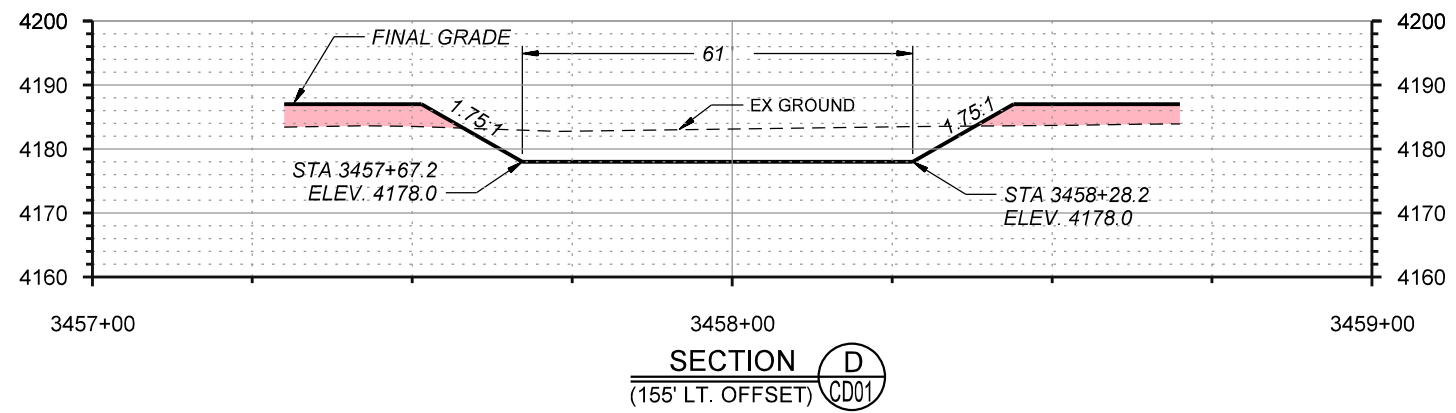

NOTE:
FOR PLAN VIEW OF SECTIONS,
SEE SHEET CD01.



		DRAWN BY: BND CHECKED BY: ADK	UNION PACIFIC RAILROAD <small>Office of Assistant Vice President Engineering Design</small>	
		DATE: 27 JULY 2015 SHEET NUMBER: CD04 of CD07		LOCATION: LAKESIDE SUBDIVISION - BR. 739.78
		DWG TITLE: CONTROL BERM EXCAVATION SECTIONS		
		<small>pw:770081807000000000056251/Lakeside_740_CD04.dgn</small>		

Color: table:\comtrsv\EGCADCADstandards\UPRR\TR\Tables\UPRR.tbl
 \comtrsv\EGCADCADstandards\UPRR\HDR\PL\OTDR\vb1\HDR-UPRR-VB1_pent.tbl.e.tbl
 pw:770081807000000000056251/Lakeside_740_CD04.dgn
 7/27/2015 3:57:58 PM

Color table: \\omtrsvr1\EGG\CADStandards\UPRR\TR\Tables\UPRR.tbl
 \\omtrsvr1\EGG\CADStandards\UPRR\TR\H\DR\Plot\DR\vb1\HDR\UPRR_VB1.pentable.tbl
 pw:7/27/2015 9:57:25 AM

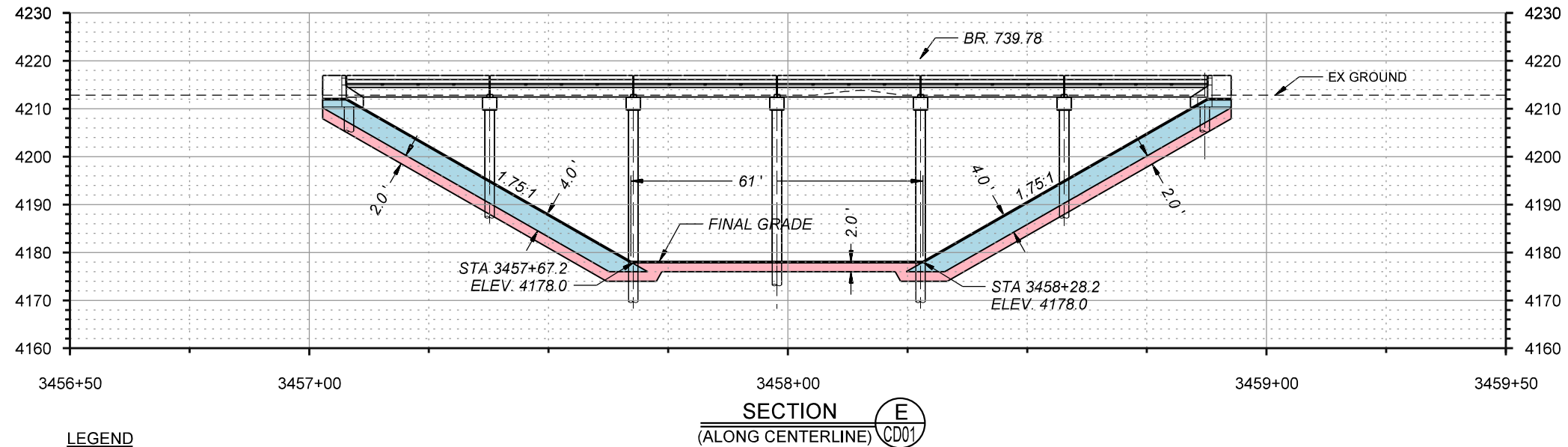

- LEGEND**
- A1 STONE
 - A3 STONE
 - B3 STONE
 - CORE STONE

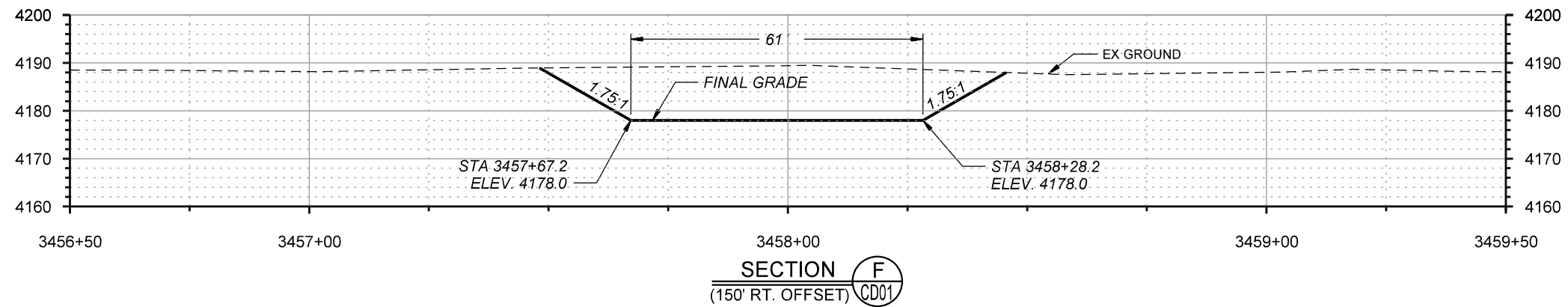

NOTE:
 FOR PLAN VIEW OF SECTIONS,
 SEE SHEET CD01.



DRAWN BY: BND
 CHECKED BY: ADK
 DATE: 27 JULY 2015
 SHEET NUMBER
 CD05 of CD07

UNION PACIFIC RAILROAD

Office of Assistant Vice President
 Engineering Design

LOCATION: LAKESIDE SUBDIVISION - BR. 739.78

DWG TITLE: CONTROL BERM EXCAVATION SECTIONS

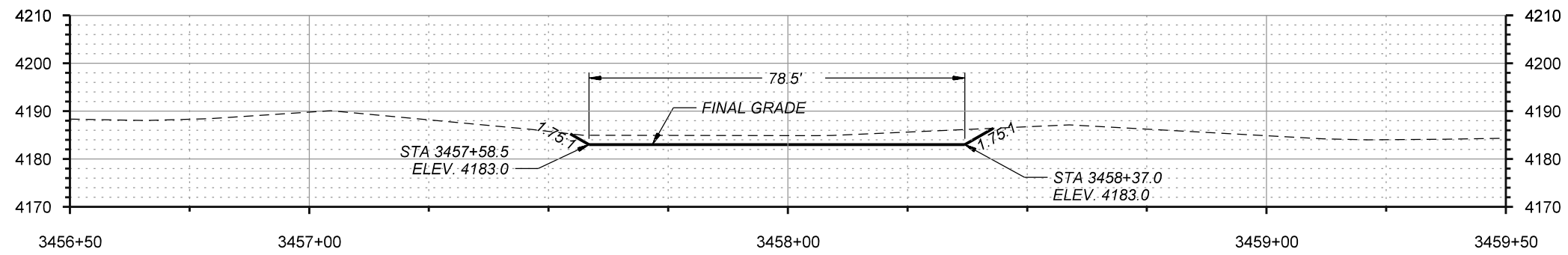

SECTION G
(230' RT. OFFSET) CD01

LEGEND

- A1 STONE
- A3 STONE
- B3 STONE
- CORE STONE

NOTE:
FOR PLAN VIEW OF SECTIONS,
SEE SHEET CD01.



DRAWN BY:
BND
CHECKED BY:
ADK
DATE:
27 JULY 2015
SHEET NUMBER
CD06 of CD07

UNION PACIFIC RAILROAD Office of Assistant Vice President
Engineering Design
LOCATION: LAKESIDE SUBDIVISION - BR. 739.78
DWG TITLE: CONTROL BERM EXCAVATION SECTIONS

Color table: \\omtrsevl\EGC\CADStandards\UPRR\TR\Tables\UPRR.tbl
 \\omtrsevl\EGC\CADStandards\UPRR\HDR\PL\OTDR\vb1\HDR-UPRR_VB1.pentable.tbl
 pw:7/27/2015 3:57:58 PM

GENERAL NOTES SHOOFLY/CONTROL BERM FILL & ARMORING

- 1) SHOOFLY ARMOR STONE SHALL BE MIN. STONE SIZE OF 1.5' DIA. (TYPE A3, B3 OR MIX OF A3/B3). PLACE ARMOR STONE TO A MINIMUM OF ELEV. 4200. SEE PLAN SHEET T001.
- 2) OBTAIN APPROVAL OF THE ENGINEER TO UTILIZE ARMOR STONE FROM THE EXISTING ROCK BERM ALONG THE TOP OF THE CAUSEWAY FOR SHOOFLY ARMOR, AS THIS BERM IS EXCAVATED AND REMOVED.
- 3) PROVIDE AND INSTALL ARMOR STONE PER UPRR RIPRAP SPECIFICATION SECTION 02271.
- 4) KEY ARMOR STONE TOGETHER BY PLACING SMALLER STONES BETWEEN LARGER STONES, AND MINIMIZING VOIDS.
- 5) WHERE CORE STONE IS PLACED ON TOP OF AN ARMOR STONE LAYER, CHOKE THE VOIDS OF THE ARMOR STONE WITH CORE STONE, PRIOR TO PLACING THE OVERLYING CORE STONE LIFTS.
- 6) PLACE AND COMPACT CORE STONE FILL IN LIFTS NOT TO EXCEED TWO FT. THICK, UNTIL FIRM AND UNYIELDING, TO THE SATISFACTION OF THE ENGINEER. REMOVE LARGEST STONES FROM CORE STONE AS REQUIRED TO COMPACT THE FILL.
- 7) WHERE FILLING FOR PERMANENT CONTROL BERM CONSTRUCTION OCCURS OVER EXISTING ARMORING, REMOVE AND REUSE EXISTING ARMOR STONES TO THE MAXIMUM EXTENT POSSIBLE.

LAKESIDE QUARRY ARMOR STONE / CORE STONE SPECIFICATIONS

STONE TYPE	W50 (TN)	STONE GRADATION (TN)		STONE GRADATION (FT)	
		LOW	HIGH	LOW	HIGH
A1	5.7	>4.3		>3.5	
A3	2.9	1.5	3.6	2.6	3.5
B3	0.9	0.3	1.5	1.5	2.6
CORE STONE/ "REJECT"	--	--	<0.3	--	<1.5

SEQUENCE OF CONSTRUCTION FOR EAST AND WEST CONTROL BERMS

THE FOLLOWING SEQUENCE OF WORK IS FOR CONTRACTOR REFERENCE ONLY. MINIMIZE THE DEVELOPMENT OF MUDWAVES AND SETTLEMENT DUE TO PLACEMENT OF FILL ON THE VERY SOFT LAKE BOTTOM SEDIMENTS. THE FOLLOWING SEQUENCE OF MATERIAL PLACEMENT IS RECOMMENDED:

- 1) FILL AT AREA ①
 - A) PLACE CORE STONE FILL TO AN ELEVATION JUST ABOVE CURRENT WATER LEVEL, AS REQUIRED TO PROVIDE A STABLE WORKING PAD FOR EQUIPMENT. FILL INTO THE LAKE BY CAREFULLY PLACING MATERIAL TO CREATE A PAD THAT EVENLY COVERS THE SOFT LAKE BOTTOM. MINIMIZE DISTURBANCE OF LAKE BOTTOM.
 - B) FILL IN EVEN LIFTS OF APPROX. 1' TO 2' THICKNESS. DO NOT ADVANCE THE FULL HEIGHT OF FILL ALL AT ONCE INTO THE WATER.
 - C) PLACE A 2' THICK CORE STONE PAD BENEATH ARMOR STONE FACING AREA ② AS SHOWN, AND BEGIN FILL PLACEMENT FOR COUNTERMEASURE BERMS, IN EVEN LIFTS.
- 2) FILL AT AREA ②
 - A) INSTALL STONE ARMOR AT FACE OF THE BERMS PER ARMORING PLAN/SECTIONS TO AN ELEVATION JUST ABOVE CURRENT WATER LEVEL.
- 3) FILL AT AREA ③
 - A) USE THE COMPLETED FILL AREAS AS A WORK PAD TO PLACE COUNTERMEASURE BERMS OF CORE STONE.
 - B) FOLLOWING LIFT/FILL RECOMMENDATIONS DESCRIBED ABOVE FOR AREA ①, PLACE CORE STONE FILL PER ENGINEER'S DIRECTION.
 - C) COUNTERMEASURE BERMS SHALL EXTEND APPROX. 45' BEYOND TOE OF CONTROL BERMS TO A MINIMUM THICKNESS OF 4 FT. (APPROX. ELEV. 4188).
 - D) ALL MATERIAL TO BE PLACED BELOW CURRENT WATER LEVEL SHALL BE INSTALLED AND APPROVED BY THE ENGINEER PRIOR TO PROCEEDING TO AREA ④.
- 4) FILL AT AREA ④
 - A) PLACE REMAINING CORE STONE AND STONE ARMOR PER THE ARMORING PLAN/SECTIONS.

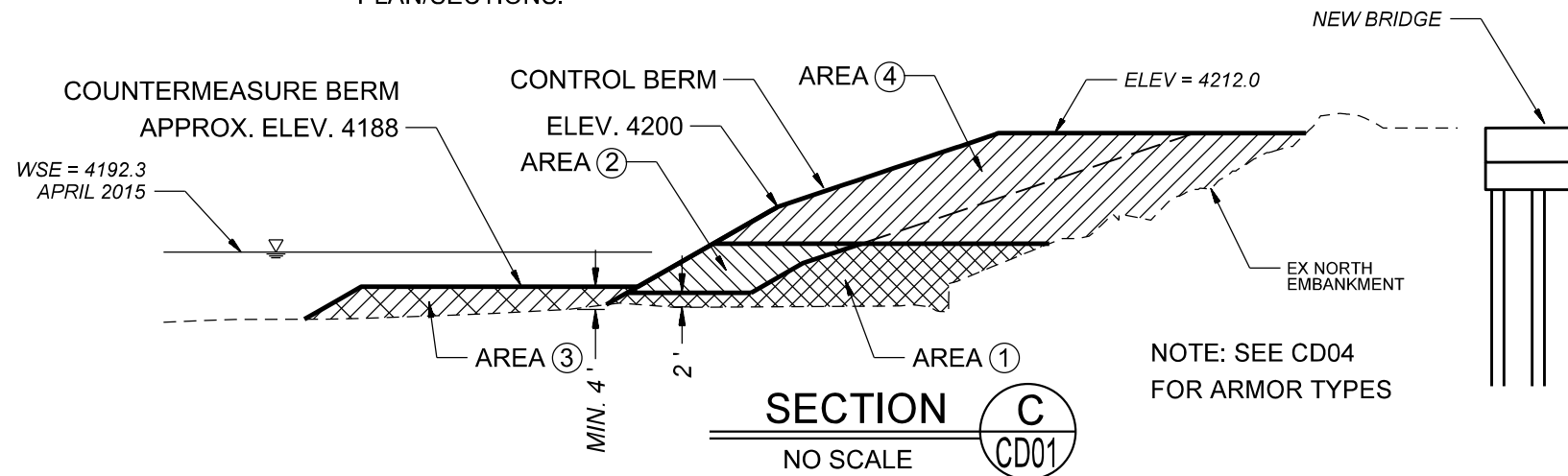

Color table: \\omtr-sv1\EGGCADStandards\UPRR\TR\Tables\UPRR.tbl
 \\omtr-sv1\EGGCADStandards\UPRR\TR\HDR\PLTDRY\vb1\HDR-UPRR-VB1.pentable.tbl
 pw:770081807000000000562517Lakeside_740_CD01.rgn
 7/27/2015 3:58:58PM

		DRAWN BY: BND	UNION PACIFIC RAILROAD Office of Assistant Vice President Engineering Design
		CHECKED BY: ADK	
DATE: 27 JULY 2015		LOCATION: LAKESIDE SUBDIVISION - BR. 739.78	DWG TITLE: ARMORING SPECIFICATIONS & DETAILS
SHEET NUMBER CD07 of CD07			

APPENDIX E

Historic and Water and Salt Balance Model Salinity Ranges Analysis

Appendix E. Historic and Water and Salt Balance Model Salinity Ranges Analysis

The purpose of this appendix is to describe the process that Union Pacific Railroad (UPRR) used to compare monitoring results directly with historical Great Salt Lake salinity values and the 2012 UPRR/USGS Model salinity values. Salinity is a calculation that represents the amount of salt in water. It is derived by dividing the amount of total dissolved solids (TDS) in the water by the density of the water and can be represented in parts per thousand (ppt) or percent.

Salinity can be defined by many methods, and state and federal agencies appear to have differing protocols. These various methods are being used by the agencies for differing purposes. Table E-1 lists the methods that were used.

Table E-1. Salinity Definitions Used by Agencies

Agency, Application	Monitoring Locations		Procedures Used to Define Salinity and Related Parameters		
	Spatial	Vertical	Salt	Density	Salinity
Utah Geological Survey (UGS), Great Salt Lake Brine Chemistry Database	UGS locations	5-foot intervals	Summation of ion concentrations	Hydrometer/Parr density meter	Calculated
U.S. Geological Survey (USGS), water and salt balance model	UGS locations	5-foot intervals	Empirical formula	UGS hydrometer/Parr density meter	Calculated
USGS, support for research studies (South Arm brine only)	USGS locations	As required	Specific connectivity	NA	Equation of state
Utah Division of Wildlife Resources, Great Salt Lake ecosystem	Ecosystem locations	Surface	NA	NA	Refractometer
		At depth	Specific connectivity	NA	Equation of state

NA = not applicable

UPRR was tasked by the conditions of its water quality certification to compare monitoring data to the historical water chemistry data reported by UGS and the salinity values produced by the UPRR/USGS water and salt balance model for the purposes of meeting project performance standards. However, the two sets of salinity values (UGS and model) cannot be directly compared, because they were calculated using two different methodologies. UGS calculated and reported discrete lake sample salinity values based on hydrometer/density meter readings and summation of ions (to represent TDS), while the water and salt balance model provides bathymetrically averaged salinity values based on UGS hydrometer or Parr density meter values and an empirical formula (to derive TDS).

This appendix describes the process that UPRR used to calculate salinity based on the water and salt balance model methodology.

E.1 Historic Salinity Range

E.1.1 UGS Data

UGS published lake elevation and lake sample elevation, density, ion concentrations (sodium, magnesium, potassium, calcium, chloride, and sulfate), weight % TDS, and salinity values for South Arm lake samples collected from 1966 to 2011 and published in the Great Salt Lake Brine Density Database (UGS 2012). The salinity values (weight % TDS) published are calculated using density (as determined by hydrometer or the Parr density meter) and TDS (as determined by summation of the ion concentrations). The published UGS water chemistry data represent each lake water sample collected at 5-foot vertical intervals at multiple locations in the South Arm, and no average South or North Arm water chemistry values are provided.

E.1.2 Method

As part of the UPRR Culvert Closure and Bridge Construction Project, UPRR used the historic density data published by UGS and conducted the following actions:

1. **Salt Load (Bathymetric) Average.** Average the densities published by UGS using a salt load methodology as used in the 1998 USGS model and documented in Water-Resources Investigation Report 00-4221 (WRI 4221), *Water and Salt Balance of Great Salt Lake, Utah, and Simulation of Water and Salt Movement through the Causeway, 1987–98* (USGS 2000), to provide an average South Arm density by sampling event corresponding to a water surface elevation (WSE).
2. **Salinity Calculation.** Apply the USGS empirical formula, as documented in WRI 4221, to the average density to calculate salinity.

These processes are described in more detail below.

Salt Load (Bathymetric) Average. UPRR analyzed the UGS-reported South Arm density and WSE data for the three South Arm sampling locations of AC3, AS2, and FB2. These three sampling locations were chosen because of the amount of data that was collected consistently over the period of record (1966 to 2011) and because these sampling locations were used by USGS and UPRR to calibrate the 2012 UPRR/USGS Model used for the project.

Discrete vertical density samples were bathymetrically averaged using the USGS salt load calculation process developed for the 1998 USGS Model as shown in Figure E-1 and documented in WRI 4221 (USGS 2000). This process calculates the total load of dissolved salt in the lake by summing each water layer load, then dividing the total salt by the total volume of the South Arm to produce an average South Arm density.

Figure E-1. Salt Load Calculation Diagram

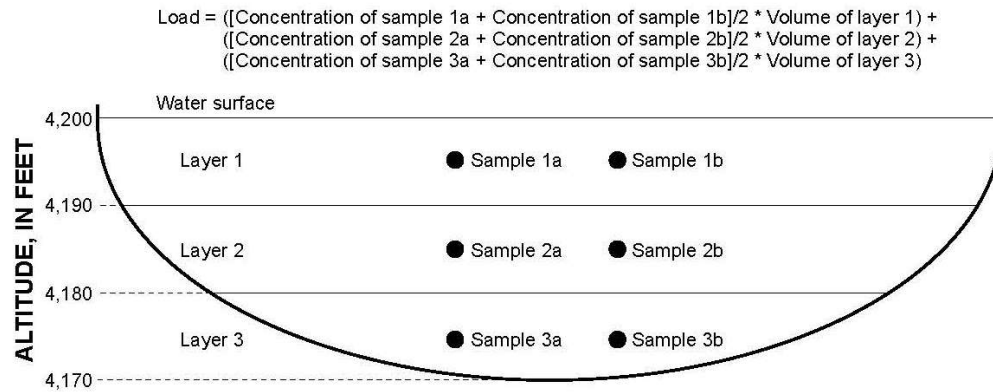

Source: USGS 2000

Salinity Calculation. Using the bathymetrically averaged density for each sampling event, UPRR calculated TDS values using the USGS empirical formula as shown below and documented in WRI 4221 (USGS 2000).

$$C = \frac{(\rho - 1)(1,000)}{0.63}$$

Where C = dissolved-solids concentration, in grams per liter (g/L)
 ρ = density at 20 degrees Celsius, in milligrams per liter (mg/L)

Then, using the measured density and calculated TDS, UPRR calculated the historic salinity using the following equation:

$$\text{Salinity, in percent} = \frac{C}{\rho(10)}$$

These historic average South Arm salinity values were plotted against the WSE reported at the time of sampling (Figure E-2).

Figure E-2. UPRR/UGS Historical South Arm Salinity Range

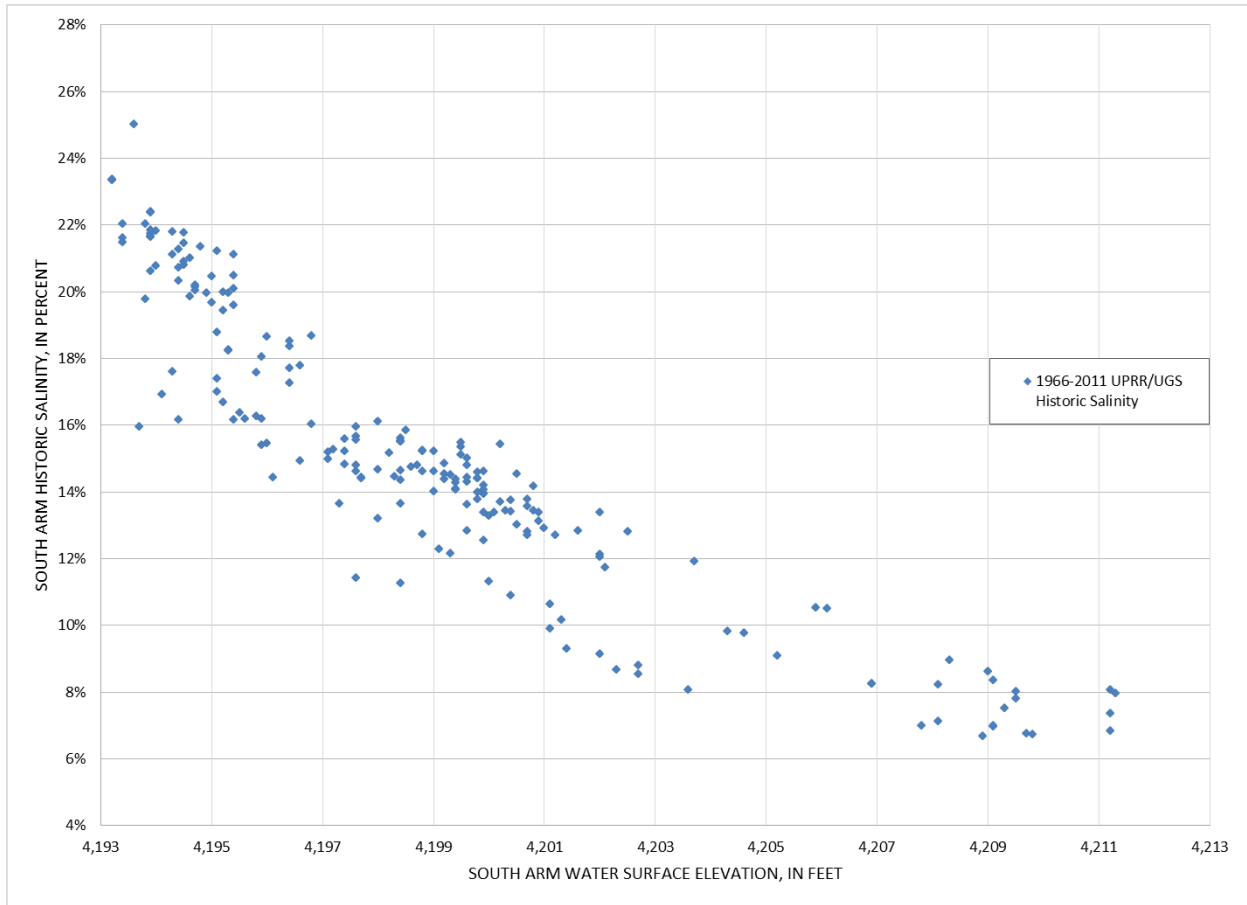

E.1.3 UGS Data Uncertainty and Error Analysis

The UGS-published historical data were qualitatively reviewed by UPRR to determine the uncertainty or error associated with collecting and analyzing the salinity data. UPRR is unaware of any published error or uncertainty analysis associated with the UGS brine density database. The following factors might affect the quality or certainty of the data. UPRR evaluated these factors and the degree of error associated with each factor.

- **Field work**
 - *Identification of exact sample locations.* Before GPS (global positioning system) devices were available to record location data, sampling locations were identified by standard navigational procedures. This led to some uncertainty with the spatial element of the data collection for the older samples in the database. However, the degree of error associated with this factor is considered low.
 - *Collection of sample at reported depths (due to bobbing and drifting boat).* This factor is more prevalent, since different bottom elevations have been reported for the same sampling location. This leads UPRR to believe that more error would be associated with reported sample depth than with other factors and that this error would affect the weighted average of the vertical water column.
- **Density data**
 - *Precision of density measurements.* This factor is considered low with regard to the degree of error. UGS used both a hydrometer and a Parr density meter to determine sample density. These methods were consistently used by UGS for many years, which leads UPRR to believe that there is little error associated with this factor, or, if there is error, the error is consistent.
- **Average salinity calculation**
 - *Calculation of salinity.* UPRR used UGS-reported density results in conjunction with the USGS empirical formula to calculate salinity to be consistent with water and salt balance salinity calculations. The use of the empirical formula could introduce high uncertainty into the salinity calculation; however, the method is consistent with the uncertainty associated with the 2012 UPRR/USGS Model salinity calculations.
 - *Methodology to average the spatial data.* The process to average the UGS density data bathymetrically does not introduce any additional error, since it is consistent with that the process used to calibrate the water and salt balance model.

Taking these factors into consideration, UPRR determined that the total error associated with collecting and analyzing the density data and calculating the average historic salinity data is 5%. Figure E-3 illustrates the historical South Arm average salinity range for use on this project and the associated 5% error.

Figure E-3. UPRR/UGS Historical South Arm Average Salinity Range and 5% Error

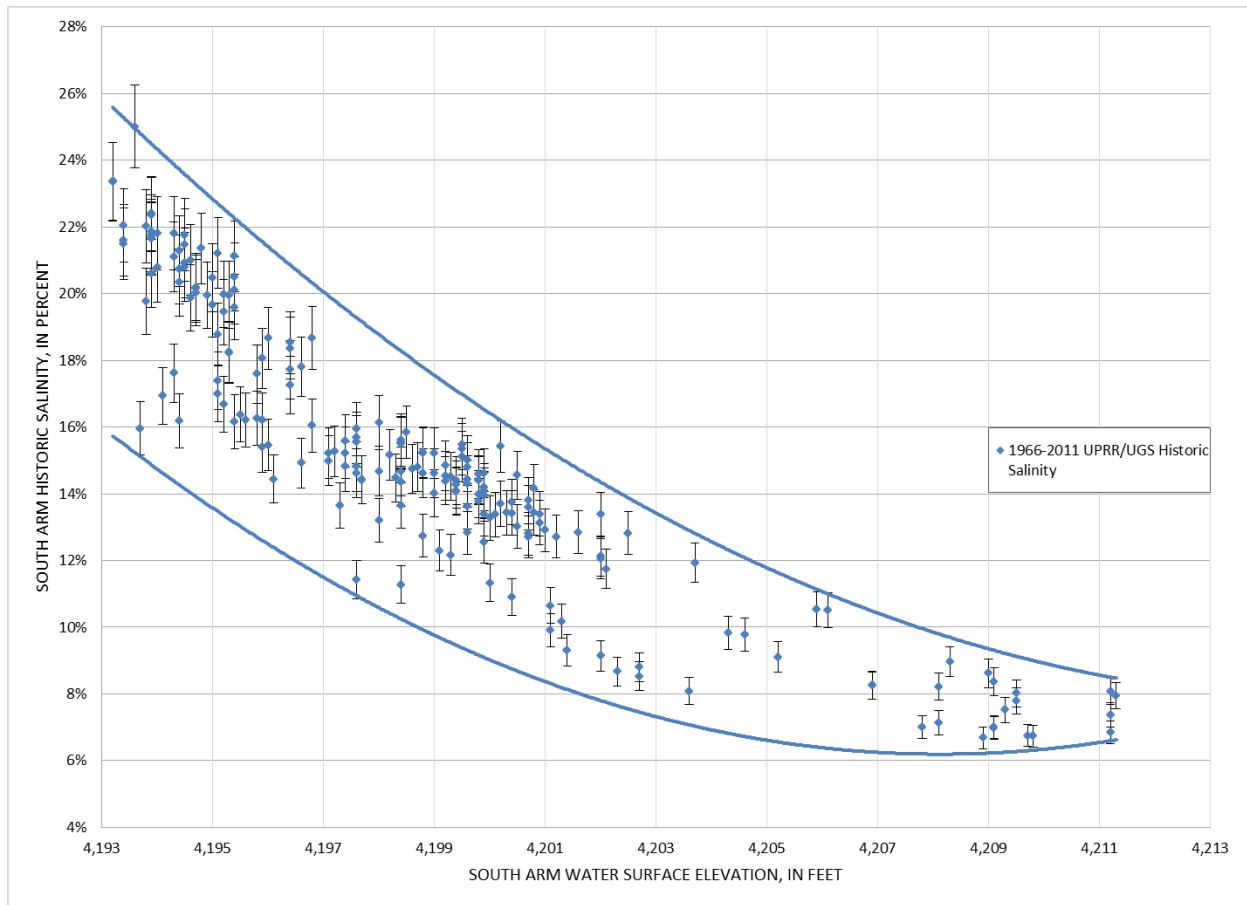

E.1.4 Historical Salinity Range Results

UPRR then applied the historical salinity range and calculated the range for each 2-foot South Arm WSE increment. These data are represented graphically in Figure E-4 and tabulated in Table E-2 on page E-13.

Figure E-4. UPRR/UGS Historical South Arm Salinity Range by 2-foot WSE Increments

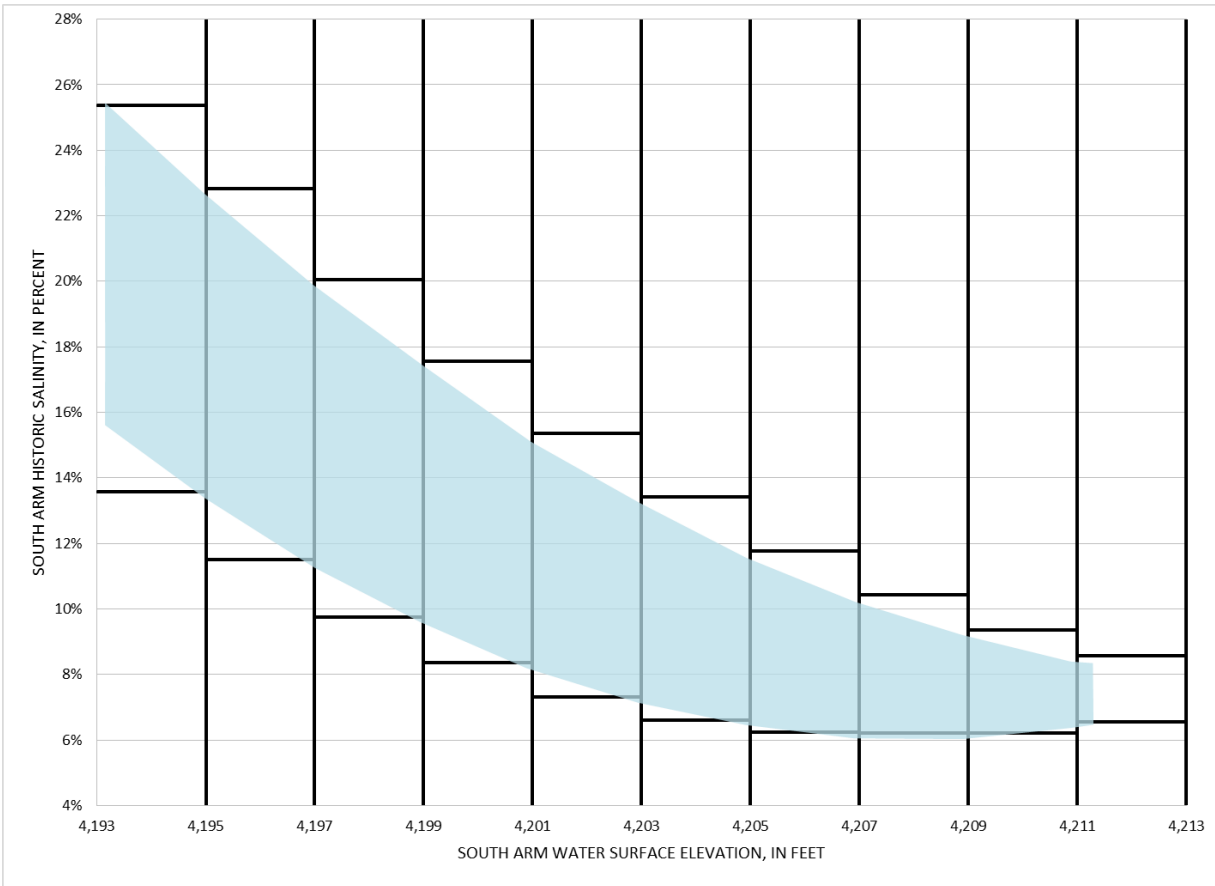

E.2 2012 UPRR/USGS Model Salinity Range

E.2.1 Introduction

UPRR used the 2012 UPRR/USGS Model results to define the salinity range for this project (UPRR 2014a). The 2012 UPRR/USGS Model simulates lake salinities for the actual inflows and evaporation rates during the period of 1987 to 2012. The two simulations described in the Bridge Evaluation Report (UPRR 2014b)—free-flowing culverts and 150-foot-long opening with an invert at 4,183 feet—were used. The model salinity results were plotted against the model WSE computed as a result of the documented inflows, estimated evaporation rates, and computed transfers between the two lake arms. In addition, a standard error was applied to the model results to represent the model uncertainties and accuracies. The development of the standard error is discussed in this appendix.

E.2.2 2012 UPRR/USGS Model Simulation Salinity Data

The 2012 UPRR/USGS Model simulations produced computed South Arm salinities for lake conditions represented by actual data for the period of 1987 to 2012. These computed salinities for the culvert simulation and 150-foot-long causeway opening simulations were presented in the Bridge Evaluation Report and are shown in Figure E-5. The figure illustrates computed South Arm salinities, for each simulation, plotted against the South Arm WSE for the period of 1987 to 2012.

Figure E-5. 2012 UPRR/USGS Model Simulation Salinity Data

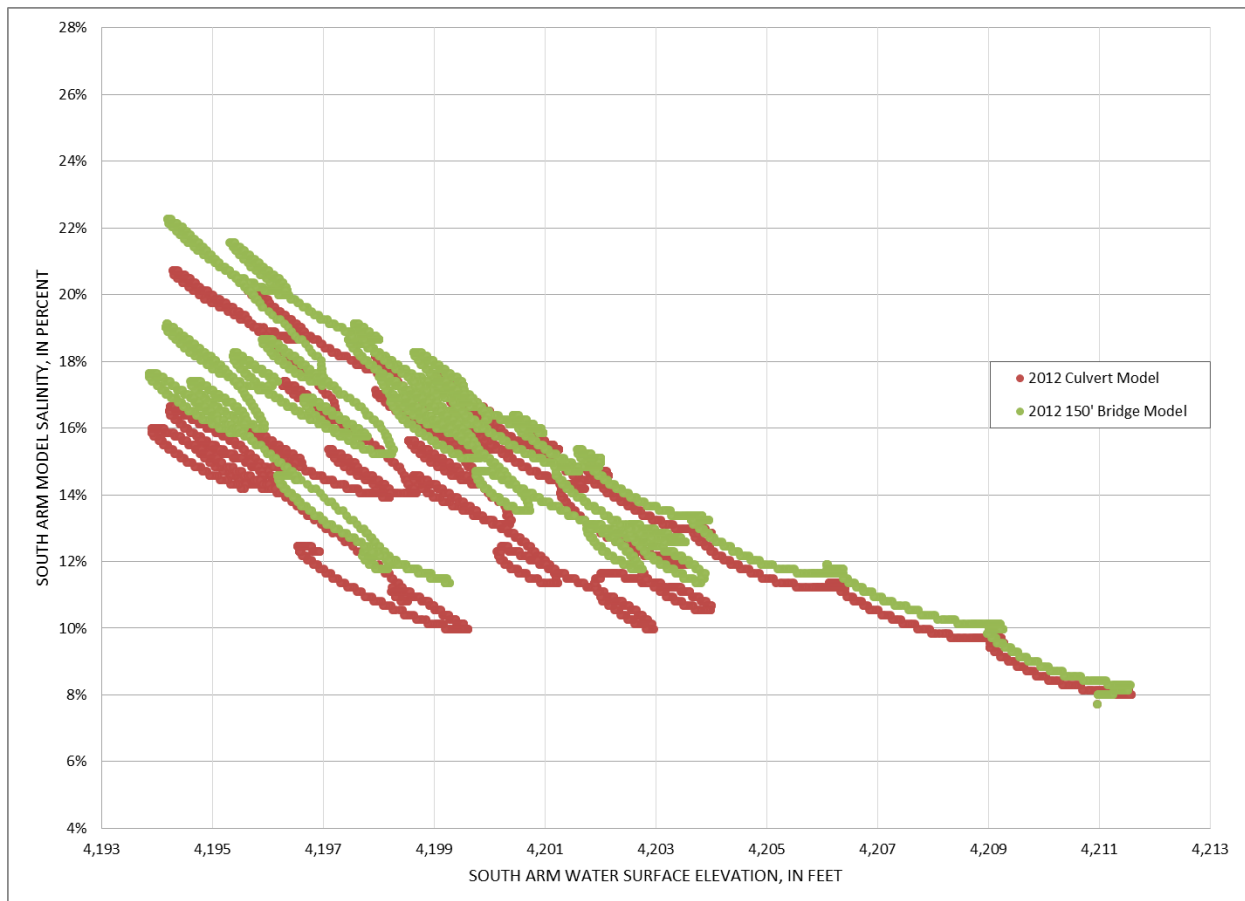

E.2.3 USGS Documented Model Sensitivity and Error Analysis

The 2012 UPRR/USGS Model was developed for the UPRR Great Salt Lake Culvert Closure and Bridge Construction Project to respond to requests from regulating agencies for a project impacts evaluation that would be conducted for varying lake WSEs and varying lake hydrology influences. The development of the 2012 UPRR/USGS Model (UPRR 2014a) adds to and recalibrates the water and salt balance model developed by USGS and documented in WRI 4221 (USGS 2000).

USGS documented sensitivity, uncertainty, and error associated with the 1998 USGS Model for various model routines and computations (USGS 2000). These are summarized below.

- Water balance
 - Measured surface inflows contributed about 70%, and estimated inflows based on watershed correlations contributed about 30%, of the total surface inflows to the lake. The measured inflows had an error of 10, and the estimated inflows had an error of about 20%. Thus, the composite error of the total surface inflow was determined to be about 13%. Because this error is compounded during the period of the model, USGS estimates that the 1998 WSE of about 4,203 feet would rise about 4 feet or fall about 4.5 feet with an increase or decrease of the surface inflows of 13%, respectively (USGS 2000, Figure A4).
 - Precipitation error was identified as 10%, resulting in about a 2.5-foot effect (higher and lower) on the WSE (USGS 2000, Figure A6).
 - Groundwater error was identified as 100%, with about a 2-foot effect (higher and lower) on the WSE (USGS 2000, Figure A6).
 - Accounting for all errors on surface water inflows, precipitation, groundwater, and evaporation, the WSE varied from a rise of about 7.5 feet to a drop of about 10 feet from the measured WSE of about 4,203 feet (USGS 2000, Figure A7).
 - The water balance was calibrated by annual adjustments to the evaporation, averaging 4%, with a range of -6% to +8%. Application of a 10% evaporation error resulted in the WSE varying from a rise of about 6 feet to a drop of about 8 feet from the measured WSE of about 4,203 feet (USGS 2000, Figure A10).
 - USGS then applied the maximum and minimum error from all sources of inflow and outflow to generate a resulting rise and fall in WSE. For the 1998 USGS Model, the greatest variation in WSE occurred from about 1990 to 1992, with about a 2-foot rise and fall. However, at the end of the model period 1998, the model-computed WSE nearly matched the measured WSE (USGS 2000, Figure A11).
- Water and salt transfer through the causeway
 - Transfer through the causeway fill is most sensitive to the fill hydraulic conductivity parameter. During 1987 to 1998, fill flow averaged 611 acre-feet per day, compared to a theoretical computed value of 501 acre-feet per day, which is a 21% reduction from the model computations. The model-computed fill flow varied the most from the calculation during the rapidly changing WSE experienced during 1987 to 1991.
 - Flows through the culvert and existing 300-foot-long bridge were estimated as:
 - South-to-north breach flow: 30%
 - North-to-south breach flow: 116%
 - South-to-north culvert flows during 1980–1983: 13%
 - North-to-south culvert flows during 1980–1983: 62%

- Salt balance model
 - After calibration of the 1998 USGS Model, the maximum difference, comparing model-computed parameters to measured data, resulted in:
 - 0.9-foot head difference
 - 0.008-g/mL (grams per milliliter) density difference
 - 0.220-BT (billion tons) precipitated North Arm salt load difference

USGS applied the flow errors in relation to a change in the breach invert required to match South Arm salinity. Application of these errors resulted in the following changes in breach invert elevations:

- South-to-north breach flow varied by 30%
 - Decrease in breach flow would result in a raise in the invert from 4,195 feet to 4,196 feet
 - Increase in breach flow would result in a lowering of the invert from 4,195 feet to 4,193.5 feet
- North-to-south breach flow varied by 116%
 - Decrease in breach flow would result in a raise in the invert from 4,195 feet to 4,196 feet
 - Increase in breach flow would result in a lowering of the invert from 4,195 feet to 4,192.5 feet

Taking these factors into consideration, UPRR determined that a 15% error associated with the 2012 UPRR/USGS Model salinity data is appropriate. Figure E-6 illustrates the 2012 UPRR/USGS Model simulation South Arm salinity range, including a 15% error, for use on this project.

Figure E-6. 2012 UPRR/USGS Model Simulation South Arm Salinity Range Including 15% Error

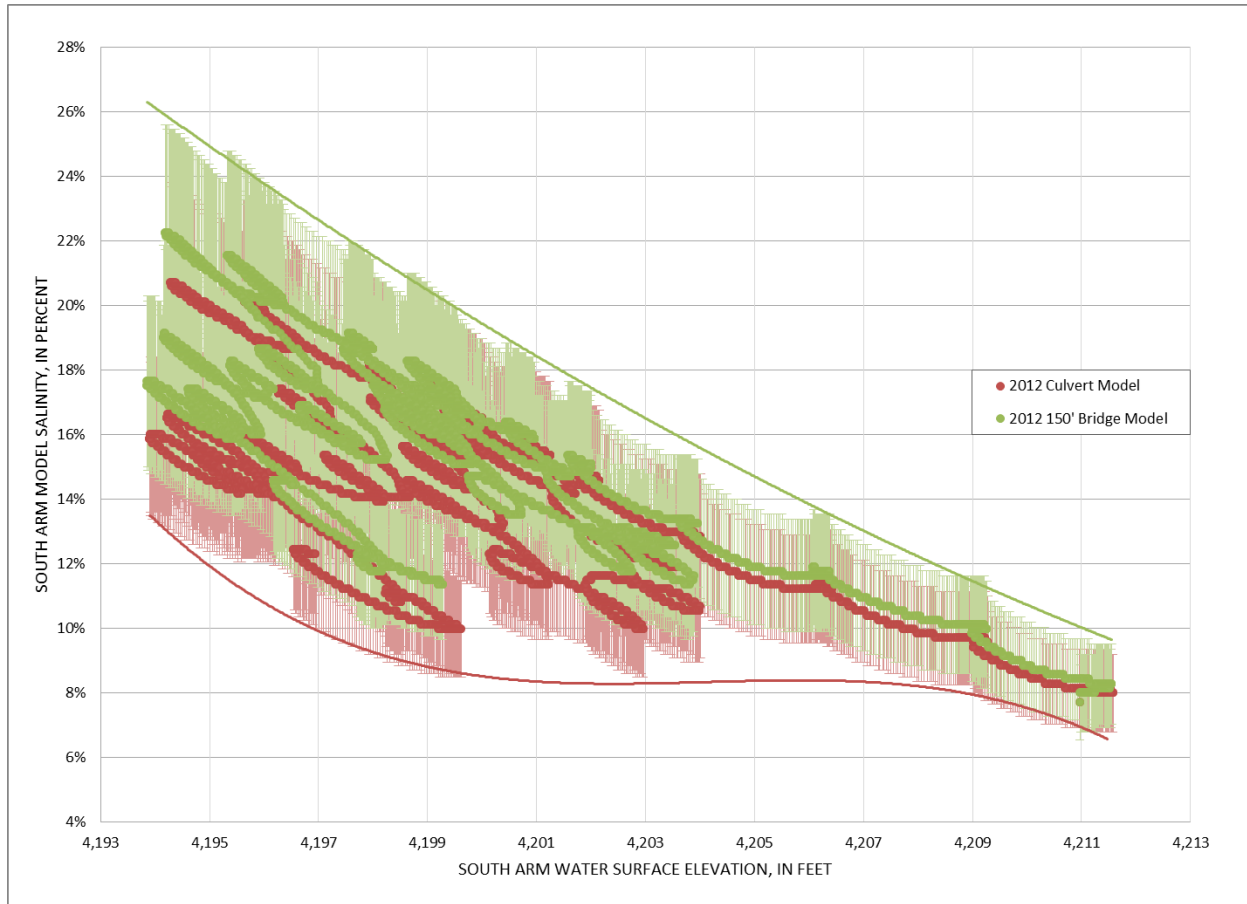

E.2.4 2012 UPRR/USGS Model Salinity Range Results

UPRR then applied the 2012 UPRR/USGS Model salinity range and calculated the range for each 2-foot South Arm WSE increment. These data are represented graphically in Figure E-7 and tabulated in Table E-2 on page E-13.

Figure E-7. 2012 UPRR/USGS Model South Arm Salinity Range by 2-foot WSE Increments

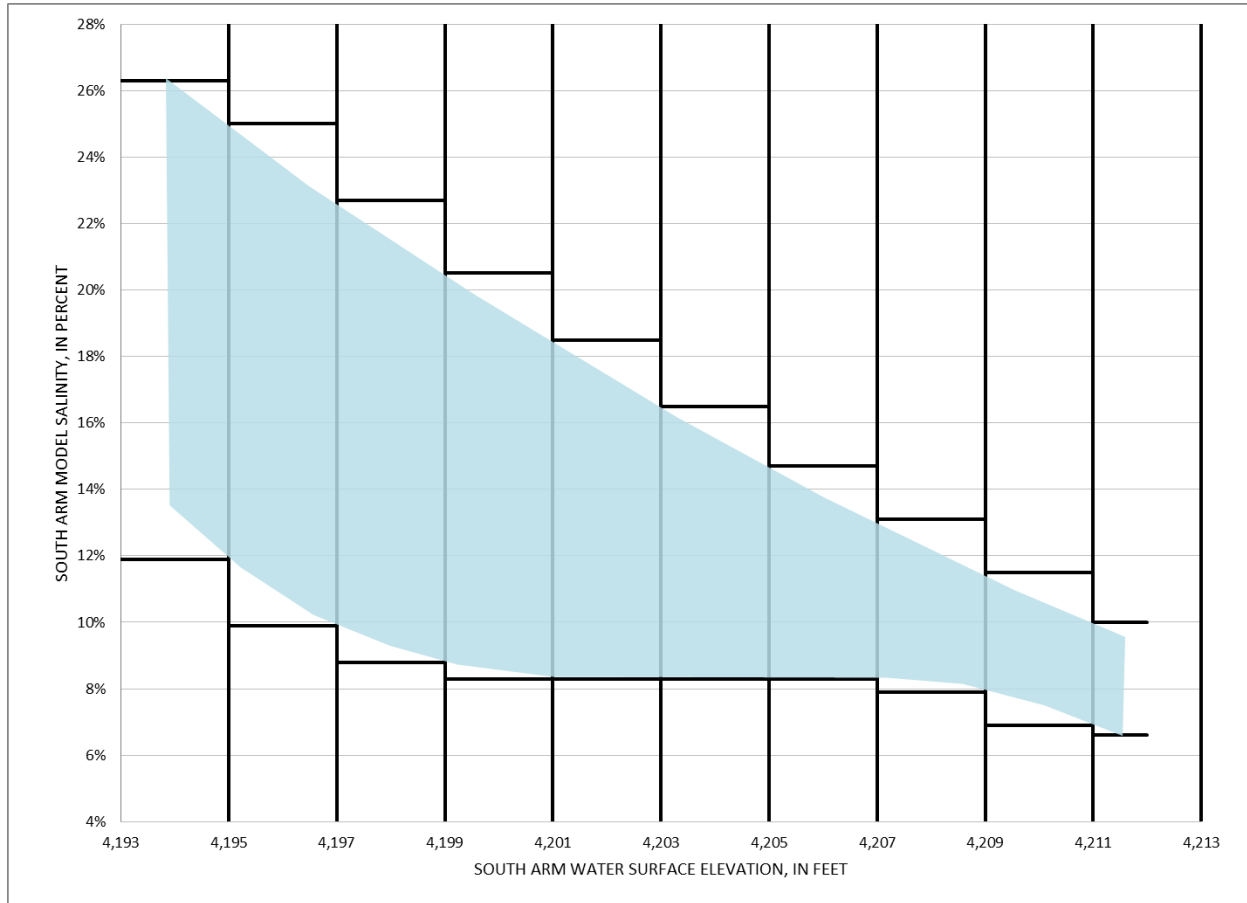

E.3 UGS/UPRR Historical and 2012 UPRR/USGS Model Salinity Range Results

Table E-2 presents the data in Figure E-4, UPRR/UGS Historical South Arm Salinity Range by 2-foot WSE Increments, and Figure E-7, 2012 UPRR/USGS Model South Arm Salinity Range by 2-foot WSE Increments, in a tabular format.

Table E-2. Summary of South Arm Historical and Model Salinity Ranges by WSE

South Arm WSE (feet)		South Arm Salinity Range (%)			
		UPRR/UGS Historical 1966–2011		2012 UPRR/USGS Model Simulation	
Lower	Upper	Minimum	Maximum	Minimum	Maximum
4,193	4,195	13.4	25.2	11.9	26.3
4,195	4,197	11.5	22.9	9.9	25.0
4,197	4,199	9.8	20.1	8.8	22.7
4,199	4,201	8.4	17.6	8.3	20.5
4,201	4,203	7.3	15.4	8.3	18.5
4,203	4,205	6.6	13.4	8.3	16.5
4,205	4,207	6.2	11.8	8.3	14.7
4,207	4,209	6.2	10.4	7.9	13.1
4,209	4,211	6.2	9.4	6.9	11.5

E.4 References

[UGS] Utah Geological Survey

2012 Great Salt Lake Brine Chemistry Database, 1966–2011.

[UPRR] Union Pacific Railroad

2014a Final Water and Salt Balance Modeling Report – Modeling Steps 1, 2, and 3. Prepared for the Union Pacific Railroad Great Salt Lake Causeway Culvert Closure and Bridge Construction Project. April 4.

2014b Bridge Evaluation Report. Prepared for the Union Pacific Railroad Great Salt Lake Causeway Culvert Closure and Bridge Construction Project. June 2.

[USGS] U.S. Geological Survey

2000 Water and Salt Balance of Great Salt Lake, Utah, and Simulation of Water and Salt Movement through the Causeway, 1987–98. Water-Resources Investigation Report 00-4221.

APPENDIX F

UFFSL Lease

SPECIAL USE LEASE AGREEMENT NO. 30000055

The State of Utah, acting by and through the Division of Forestry, Fire and State Lands (“Division”), LESSOR, hereby Leases to Union Pacific Railroad Company, LESSEE, the tracts of Sovereign land (the “Land”) at Great Salt Lake, State of Utah, described in Exhibit A attached hereto and incorporated herein by reference.

TO HAVE AND TO HOLD for a term of thirty (30) years, beginning the 17th day of September, 2015 and expiring the 17th day of September, 2045 subject to any and all existing valid rights in said Land and subject also to the following terms and conditions. LESSOR and LESSEE enter into this Special Use Lease Agreement (“Lease”) for the purpose that LESSEE maintain and develop the Land in the manner hereinafter described and consistent with governing law.

LESSOR acknowledges that LESSEE contends that LESSEE has the right to use the Land. LESSOR does not agree with LESSEE's contention. The entry into this Lease by LESSOR and/or LESSEE shall not constitute a waiver by either party of any existing interest or rights in and to the Land derived from sources or circumstances other than this Lease.

1. **Purpose of Lease.** The Land shall be used by LESSEE for the purpose of a railroad line and related railroad purposes, including telecommunications facilities supporting railroad purposes.

2. **Structures.** LESSEE agrees that there will be no new automobile roads, recreational trails, or permanent structures constructed on the Land described unless specifically authorized in this Lease or in writing by the Division. Any items authorized under a permit contemplated under Sections 13 or 14 below shall be considered authorized in this Lease. This Lease expressly authorizes and permits the construction of a bridge, bridge opening, control berm, channel, railroad tracks, and related facilities within the Land on the west end of the causeway, and authorizes existing structures and related facilities upon the Land.

3. **Rental.** LESSEE shall pay to the LESSOR as rental for the Land the sum of \$ [REDACTED] per annum for the first five (5) year period of this Lease and thereafter the sum of rent per annum that shall be established pursuant to Section 5. LESSOR acknowledges the receipt of [REDACTED] which is the rental for the first year, and which includes the \$300.00 application fee. Rental for the year shall be due September 17. Failure to pay the rental one month from the date such rent is due, and upon expiration of a written notice requiring performance within thirty (30) days, shall constitute a breach of this Lease.

4. **Renewal.** At the expiration of the thirty-year Lease term, absent written notice prior to the expiration of the Lease term by either party to the contrary, the Lease will be renewed for an additional thirty-year term.

5. **Rental Adjustments.** LESSEE agrees that LESSOR shall have the right to adjust the annual rental provided for in Section 3 at the end of the first five (5) year period, and every five (5) years thereafter, as LESSOR shall deem to be reasonably necessary in the best interest of the State. Said adjustment shall be calculated by the following method:

a. At the end of any five-year period, the increase in annual rental shall be the percentage increase of the CPI-U over such five-year period pursuant to Division rule R652-30-400(4). At that time, however, the increased annual rental shall not exceed the prior annual rental by more than five percent (5%).

b. At the end of the first twenty (20) year period and every twenty (20) years thereafter, if LESSOR elects, LESSOR may obtain an appraisal of the Land and propose a revised annual rental to LESSEE on the basis thereof, excluding the value of improvements. If LESSEE does not agree to the proposed revised annual rental, LESSEE may obtain its own appraisal and propose an alternative revised annual rental. If the parties fail to agree on a revised annual rental, they shall jointly select a third appraiser who shall set the revised annual rental at an amount equal to or between LESSOR's and LESSEE's proposed revised annual rental based upon the fair market value of the Land. Following an adjustment of the annual rental to this Section 5(b), subsequent adjustments of the annual rental shall be performed in accordance with Section 5(a), above, subject to LESSOR's rights to reappraise and adjust the annual rental under this Section 5(b).

6. **Modification of Improvements.** This Lease does not grant the LESSEE the right to modify Lease improvements that materially impact navigation or circulation without prior authorization from LESSOR, except for any work or modifications completed pursuant to any permit contemplated under Sections 13 or 14 below. Other modifications to Lease improvements may be made after prior notice to LESSOR.

7. **Sovereign Lands.** Nothing in this Lease restricts the right and duty of LESSOR to manage and control sovereign lands adjacent to and near the Land, which are the beds of navigable bodies of water. LESSEE hereby waives any and all claims of whatever nature which may arise directly or indirectly from activities of LESSOR to control, influence or manage, through activities on sovereign lands other than the Land, the level of any waters over sovereign lands, including but not limited to all breaching, diking, pumping, diversion, upstream water development, flood control works, granting of rights-of-way, wildlife or recreation development or any other management activities or programs that the State deems appropriate. LESSEE hereby acknowledges that the level of any waters over sovereign lands may fluctuate either naturally or due to management activities of the State of Utah. LESSEE acknowledges that LESSOR's activities and programs on lands other than the Land, which influence the water levels of any waters, including the Great Salt Lake, are allowed under this Lease, and LESSEE shall cooperate with such activities and programs to the extent required under Section 14 below.

8. **Limited Rights.** The rights granted in this Lease are strictly limited to the Land. This Lease does not in any way encumber or limit LESSOR'S ability to manage or use as it sees fit any sovereign lands in the vicinity of the Land, including the acreage adjacent to and surrounding the Land. The LESSOR makes no express or implied representation or promise that management of surrounding sovereign lands, including lands adjacent to the Land, will be restricted in any way by virtue of this Lease. LESSEE concedes that its rights are restricted to the Land and that no buffer zone for viewshed or any other purpose is created by this Lease. LESSEE acknowledges that the Land is sufficient in size to allow LESSEE to accomplish its purposes under this Lease.

9. **Other Jurisdictions.** LESSEE, in exercising the privileges granted by this Lease shall comply with the provisions of all valid Federal, State, County and Municipal laws, ordinances, and regulations which are legally applicable both to the Land and to the operations covered in this Lease and are not preempted by the jurisdiction of the Surface Transportation Board (the "Board") over LESSEE under the Interstate Commerce Commission Termination Act (the "Act") or otherwise preempted under any other Federal law.

10. **Army Corps Permits.** If LESSEE secures any U. S. Army Corps permit for activities on the Land, the LESSEE shall notify the LESSOR in writing within 15 days. Control of invasive species may occur on the Land by chemical application or mechanical means with minimal disturbance. Chemical treatment must be done in consultation with LESSOR.

11. **Access.** LESSEE agrees to permit LESSOR access to and upon the Land at all reasonable times for all lawful and proper purposes not inconsistent with the intent of this Lease or with the reasonable exercise and enjoyment by the LESSEE of the rights and privileges granted herein. LESSOR agrees to avoid interfering with LESSEE's operations and to comply with LESSEE's safety requirements to ensure the safety of LESSOR's and LESSEE's personnel.

12. **Public Access to Sovereign Lands.** The LESSEE may exclude the public from improvements constructed within the Land. Provided, however, access to sovereign lands adjacent to the Land is allowed, but only over the Land to the extent accessed under the bridge contemplated under the Permit (below defined) or accessed in connection with a modification contemplated under Section 14(c) below and in a manner approved by LESSEE as compliant with LESSEE's safety requirements and not interfering with LESSEE's operations on the Land.

13. **Other Permit Conditions.** LESSEE shall comply with all conditions in:

a. The permit to temporarily close the East Culvert issued by the Department of the Army, U.S. Army Corps of Engineers, Certification No. SPK 2011-00755, dated December 6, 2013, to the extent currently applicable to LESSEE's activities on the Land;

b. The "Approval of the 401 Water Quality Certification with Conditions," issued by the Utah Department of Environmental Quality, Division of Water Quality, Certification No. SPK 2011-00755, dated December 16, 2013;

c. Any other permit applied for by LESSEE and issued to LESSEE by the Department of the Army, U.S. Army Corp of Engineers under the authority of 33 USC § 1344 associated with the Land; and

d. Any other certification applied for by LESSEE and issued to LESSEE by the Utah Department of Environmental Quality, Division of Water Quality under the authority of 33 USC § 1341.

14. **Circulation of Brines and Navigation.** LESSEE shall allow for circulation of brine and water and public navigation through the Land and improvements, to the extent provided as follows:

a. It is anticipated that proposed improvements to be constructed by LESSEE including the bridge, bridge opening, control berm, and channel contemplated in a permit under Section 13(c) above (such permit covering the bridge, bridge opening, control berm, and channel, the "Permit"), shall allow for the circulation of brine and water through the Land and improvements to the extent required by the items noted in Section 13 above. After construction of the bridge, bridge opening, control berm, and channel, during the compliance and monitoring period provided under the Permit (such period, the "Monitoring Period"), LESSEE shall maintain the bridge, bridge opening, control berm, and channel in accordance with the requirements of the Permit. Additionally, after the end of the Monitoring Period, LESSEE shall maintain the bridge, control berm, and channel in the condition existing at the end of the Monitoring Period. Nothing in this provision is intended to relieve LESSEE of any obligation required by the items noted in Section 13 above.

b. After the Monitoring Period, upon request by LESSOR, LESSEE shall permit LESSOR to enter upon the Land and/or improvements in order to modify the control berm, bridge opening, or channel contemplated in the Permit. Provided, however, that access by LESSOR onto the Land and/or improvements and activities of LESSOR thereon shall be in compliance with all of LESSEE's then-current safety requirements and shall be conducted in a manner to avoid interference with LESSEE's operations on the Land and/or improvements. Any contractor or assignee of LESSOR entering onto the Land and/or improvements shall first enter into LESSEE's then-current right of entry agreement which shall, among other things, require the contractor to comply with all of LESSEE's safety requirements and avoid interference with LESSEE's operations. After the Monitoring Period, LESSOR's modification, after request, of the control berm, bridge opening, or channel, shall relieve LESSEE of its obligations related to maintenance of the control berm, bridge opening, and channel, and before making any such modification LESSOR shall first enter into a separate agreement with LESSEE concerning such modification under which LESSOR assumes responsibility for all further operation, maintenance and repair of the control berm, bridge opening and channel.

c. After the Monitoring Period, upon request by LESSOR, in addition to, or instead of, modifying the control berm, bridge opening, or channel pursuant to Section 14(b) above, LESSEE shall permit LESSOR to enter upon the Land to modify improvements to facilitate circulation of brine and water or navigation through the Land and/or improvements. The details of any such modification project would be covered under a separate agreement between LESSOR and LESSEE. Such separate agreement would include, without limitation, a requirement that (i) the design and construction plan for any such modification of improvements shall be subject to LESSEE's approval, which approval shall not be unreasonably withheld; (ii) any such modifications shall avoid interference with LESSEE's operations on the Land and/or improvements and shall be completed in compliance with all of LESSEE's safety requirements; (iii) any access by LESSOR onto the Land and/or improvements and activities of LESSOR thereon shall be in compliance with all of LESSEE's then-current safety requirements and shall be conducted in a manner to avoid any interference with LESSEE's operations on the Land and/or improvements; (iv) any contractor or assignee of LESSOR entering onto the Land and/or improvements shall first enter into LESSEE's then-current right of entry agreement which shall, among other things, require the contractor to comply with all of LESSEE's safety requirements and avoid interference with LESSEE's operations; (v) following any modifications to improvements made by LESSOR under this Section 14(c), LESSOR (not LESSEE) shall be

responsible to maintain any such modified improvements at LESSOR's expense; and (vi) all costs of LESSEE in connection with any such modifications under this Section 14(c), including any review, maintenance, increased operating or other costs of LESSEE related thereto, shall be paid by LESSOR.

15. **Breach.** In the event of a breach by LESSEE, defined as the failure by LESSEE to perform any obligation hereunder when due, and LESSEE's failure to cure such failure within thirty (30) days of receiving notice from LESSOR unless such failure cannot reasonably be cured within the thirty (30) day period, in which case LESSEE shall not be deemed in breach if LESSEE commences efforts to cure the failure within such thirty (30) day period and thereafter continues its efforts to cure, LESSOR may at any time do any one or more of the following:

- a. Terminate this Lease. Such termination shall be effective ten (10) days after LESSOR giving written notice of termination.
- b. Maintain this Lease in full force and effect and recover any rental, royalty, or other consideration as it becomes due regardless of whether LESSEE shall have abandoned the Land.
- c. Seek damages for any breaches with or without terminating this Lease.
- d. Exercise any other right or remedy which LESSOR may have at law or equity, provided, notwithstanding any provision in this Lease to the contrary, nothing in this Lease, nor the breach, termination or expiration of this Lease, shall give LESSOR the right to interfere with LESSEE's rights, if any, to possession and use of the Land that exist independent of this Lease. LESSOR acknowledges that LESSEE contends that LESSOR and LESSEE must first adjudicate the rights of LESSOR and LESSEE in the Land and to operate over the Land beyond those rights derived from the Lease before LESSOR may challenge LESSEE's possession of the Land or otherwise interfere with LESSEE's operations on the Land, and such adjudication shall not be limited by any requirements of Section 43 below.

16. **No Survival.** All obligations of LESSEE and LESSOR to be performed prior to the expiration or earlier termination shall cease upon the termination or expiration of this Lease. Notwithstanding any clauses of this Lease which require performance by LESSEE or LESSOR beyond the termination or expiration date of this Lease, no clauses or obligations binding LESSEE or LESSOR shall survive such termination or expiration. However, upon expiration or earlier termination of this Lease, the rights of LESSEE and of all persons, firms, corporations, and entities claiming under LESSEE in and to the Land, to the extent such rights are derived from this Lease, shall cease. Provided, however, nothing in this Section 16 shall affect any obligations which LESSEE may have independent of this Lease to comply with any terms or conditions of any permit contemplated in Sections 13 or 14 above.

17. **Lessor's Right to Cure Breaches.** If LESSEE fails to perform and is in breach of any undertaking or promise contained herein, including those set forth in any plan of development, the LESSOR shall have the option, but is not obligated, while this Lease remains in effect, to make such performance after giving 30 days written notice to the LESSEE. The LESSOR's costs and expense to correct LESSEE's failure to perform shall, so long as this Lease has not been

terminated by LESSOR or LESSEE, be reimbursed by LESSEE and shall be immediately due and payable, together with interest accruing from the date such cost or expense is incurred.

19. **Remedies Cumulative.** The remedies specified in Section 15 above to which the LESSOR may resort under the terms of this Lease are cumulative and are not intended to be exclusive of any other remedies or means of redress to which LESSOR may lawfully be entitled in case of any breach or threatened breach by LESSEE of any provision of this Lease, subject to the limitations set forth in Section 15 and elsewhere in this Lease.

20. **Force Majeure.** The LESSEE's failure to comply with any of the obligations under this Lease shall be excused only if due to causes beyond LESSEE's control and without the fault or negligence of the LESSEE, including acts of God, acts of the public enemy, acts of any government, fires, floods, epidemics and strikes.

21. **Antiquities.** It is hereby understood and agreed that all treasure-trove and all articles of antiquity in or upon the Land are and shall remain the property of the State of Utah. LESSEE shall report any discovery by LESSEE or LESSEE's employees, agents, sublessees, contractors, subcontractors or licensees, of a "site" or "specimen" to LESSOR and the Division of State History in compliance with the provisions of Section 9-8-305, Utah Code Annotated (1953), as amended and take such action as may be required for the protection of said site or specimen.

22. **Removal of Improvements.** LESSEE shall have the right to remove any improvements and any personal property placed on the Land by LESSEE. LESSOR acknowledges LESSEE is a rail carrier under the Act, and LESSEE contends LESSEE has a duty under the Act to use the Land in LESSEE's performance of its freight rail carrier services. Notwithstanding any other provision in this Lease to the contrary, LESSOR may not dispossess LESSEE of the Land or interfere with LESSEE's operations on the Land by virtue of this Lease. If LESSEE abandons its use of the Land, defined herein as LESSEE's ceasing to use the Land for its railroad operations and notifying LESSOR in writing of LESSEE's intention not to continue use of the Land for railroad operations at any time in the future, LESSOR may, subject to adjudication of the rights of LESSOR and LESSEE in the Land aside from any rights derived from this Lease, remove any improvements and personal property on the Land or retain any improvements and personal property on the Land remaining on the date six (6) months after the effective date of LESSEE's abandonment of the Land.

23. **Liability and Indemnification.** LESSEE agrees to protect, indemnify and save harmless the LESSOR, its agents and employees, from and against all claims, demands, damages, and causes of action of every kind or character on account of bodily injuries, death, or damage to property, in each case to the extent occurring on the Land and arising out of LESSEE's or LESSEE's employees', agents', sublessees', contractors', subcontractors', or licensees' negligent actions or intentional misconduct on the Land during the term of this Lease. Provided, however, this indemnity shall not extend to claims, demands, damages and causes of action arising out of LESSEE's actions to comply with any permit issued to LESSEE as contemplated under Sections 13 or 14 above. In the event LESSEE fails to comply with any permit obligation set forth in Sections 13 or 14 above, the sole remedy of LESSOR by virtue of the Lease (notwithstanding any language to the contrary in Section 15 above or otherwise in this Lease) shall be to pursue injunctive relief securing LESSEE's performance of its obligations to comply with any such

permit. Provided further, however, nothing in this Lease is intended to limit any right or remedy available to LESSOR or any agency of LESSOR under any permit contemplated under Sections 13 or 14 above. LESSOR agrees to protect, indemnify and save harmless the LESSEE, its agents and employees, from and against all claims, demands, damages, and causes of action of every kind or character on account of bodily injuries, death, or damage to property, in each case to the extent occurring on the Land and arising out of LESSOR's or LESSOR's employees', agents', contractors', or subcontractors' negligent actions or intentional misconduct on the Land during the term of this Lease. However, neither Party shall be indemnified hereunder for any loss, liability, damage, or expense resulting from its sole negligence or willful misconduct.

24. **Assignment and Sublease.** LESSEE shall not assign this Lease, in whole or in part, nor sublease the Land, nor allow unauthorized or commercial use of the Land without obtaining the prior written consent of LESSOR. The acquisition or assumption by another party under an agreement with the LESSEE of any right or obligation of the LESSEE under this Lease shall be ineffective as to the LESSOR unless and until LESSOR shall have been notified of such agreement and shall have approved the same in writing. Approval shall not be unreasonably withheld, and in no case shall such approval operate to relieve the LESSEE of the responsibilities or liabilities assumed by LESSEE hereunder.

a. Consent of the LESSOR to an assignment or transfer shall not constitute a waiver of the LESSOR's right to approve subsequent assignments or transfers. The acceptance by LESSOR of payment or performance following an assignment or transfer shall not constitute consent to any assignment or transfer, and LESSOR's consent shall be evidenced only in writing.

b. An assignment does not constitute a new Lease but is continuation of the existing Lease.

25. **Title.** LESSOR claims title in fee simple, but does not warrant to LESSEE the validity of title to the Land. LESSEE shall have no claim for damages or refund against the LESSOR for any claimed failure or deficiency of LESSOR's title to the Land or for interference by any third party. LESSEE takes possession subject to all existing encumbrances, rights-of-way, or encroachments as may exist or be of record.

26. **Water Rights.** If LESSEE shall initiate or establish any water right on the Land, such right shall become an appurtenance of the Land. LESSEE agrees that any existing application to appropriate water on the Land shall be transferred to the LESSOR after the application has been completed, without any cost to the LESSOR. It is expressly understood and agreed that this Lease does not confer any rights upon LESSEE to use any water presently developed on the Land.

27. **Fire.** LESSEE shall at all times observe reasonable precautions to prevent fire on the Land and shall comply with all applicable laws and regulations of any governmental agency having jurisdiction subject to the limitations noted in Section 9 above. In the event of a fire on the Land proximately caused by LESSEE, its servants, employees, agents, sublessees, assignees or licensees which necessitates suppression action, LESSEE agrees to reimburse LESSOR for the cost of such fire suppression action.

28. **Campfire Prohibition.** LESSEE agrees that no campfires will be allowed on the Land.

29. **Sanitation.** LESSEE shall comply with any and all legally applicable, valid sanitation and pollution regulations prescribed by any governmental agency having jurisdiction, in each case to the extent they are legally applicable both to the Land and to the operations of LESSEE on the Land and are not preempted by the exclusive jurisdiction of the Board under the Act or otherwise preempted under any other Federal law. Surface areas on the Land will be maintained and cleaned of trash, debris, and waste deposited by LESSEE.

30. **Waste.** LESSEE shall neither commit nor permit any waste on the Land.

31. **Pollution.** LESSEE shall be bound by all applicable environmental regulatory programs, including those related to air quality, water pollution and water quality, solid and hazardous waste management and underground storage tanks, and other conditions as contained in the provisions, conditions, and rules and regulations developed under authority of Title 19, Utah Code Annotated (1953) as amended, in each case to the extent applicable to the Land and the operations covered in the Lease and to the extent they are not preempted by the exclusive jurisdiction of the Board over LESSEE under the Act or otherwise preempted under any other Federal law.

32. **Clean Water Act.** LESSEE agrees to abide by and comply with all legally applicable federal, state and local laws, including but not limited to Utah's State Boating Act, Title 73 Chapter 18 of the Utah Code, and the Federal Water Pollution Control Act (Clean Water Act), in each case to the extent such laws are applicable both to the Land and to the operations of LESSEE on the Land and are not preempted by the exclusive jurisdiction of the Board under the Act or otherwise preempted under any other Federal law.

33. **Hazardous Substances.**

a. LESSEE shall not make, or authorize to be made, any filling in of the Land with any deposit of refuse, garbage, waste matter, chemical, biological or other wastes, hydrocarbons, any other pollutants, within or upon the Land, except as approved in writing by the LESSOR.

b. LESSEE shall not keep on or about the Land any substances now or hereinafter designated as or containing components now or hereinafter designated as hazardous, toxic, dangerous, or harmful, and/or which are subject to regulation as hazardous, toxic, dangerous, or harmful by any federal, state or local law, regulation, statute or ordinance (hereinafter collectively referred to as "Hazardous Substances") unless such are necessary to carry out LESSEE's permitted use under Section 1 above and unless LESSEE fully complies with all federal, state and local laws, regulations, statutes, and ordinances, now in existence or as subsequently enacted or amended and legally applicable to LESSEE's operations and not preempted by the exclusive jurisdiction of the Board under the Act or otherwise preempted under any other Federal law and unless LESSEE has notified LESSOR of all Hazardous Substances necessary to carry out such purposes which will be kept or used on the Land.

c. LESSEE shall:

i. Where required by applicable laws and regulations, promptly provide any notices of (A) spills or releases of any Hazardous Substances affecting the Land and in quantities for which

reporting is required, (B) all failures to comply with any federal, state or local law, regulation or ordinance, as now enacted or as subsequently enacted or amended, (C) all inspections of the Land by, or any correspondence, orders, citations, or notifications from any regulatory entity concerning Hazardous Substances affecting the Land, (D) all regulatory orders or fines or all response or interim cleanup actions taken by or proposed to be taken by any government entity or private party concerning the Land; and

ii. On request, provide copies to the LESSOR of any and all non-privileged, correspondence, pleadings, and/or reports received by or required of LESSEE or issued or written by LESSEE or on LESSEE's behalf with respect to a spill or release of Hazardous Substances related to the Land.

d. LESSEE shall be fully and completely liable to the LESSOR, and shall indemnify, defend, and save harmless LESSOR and its agencies, employees, officers, and agents with respect to any and all third-party claims, costs, fees (including attorneys' fees and costs), penalties (civil and criminal), and cleanup costs assessed against or imposed on LESSOR as a result of LESSEE's or LESSEE's employees, agents, assigns, sublessees, contractors, subcontractors, licensees or invitees negligent use, disposal, transportation, generation and/or sale of Hazardous Substances and/or arising from the release by LESSEE of any Hazardous Substance on the Land.

e. The LESSEE shall comply with the Toxic Substances Control Act of 1976, as amended (15 U.S.C. 2601, et seq.) with regard to any toxic substances that are used, generated by or stored on the Land. Additionally, any release of toxic substances (leaks, spills, etc.) in excess of the reportable quantity established by 40 CFR, part 117, shall be reported as required by the Comprehensive Environmental Response, Compensation and Liability Act of 1980, Section 102b. A copy of any report required or requested by any Federal agency or State government as a result of a reportable release or spill of any toxic substances shall be furnished to the LESSOR's authorized officer upon request.

34. **No Partnership.** The LESSOR is not a partner nor a joint venturer with the LESSEE in connection with the activities conducted and business carried on under this Lease and the LESSOR shall have no obligation with respect to the LESSEE's debts or other liabilities. This Lease is for the benefit of LESSOR and LESSEE and nothing in this Lease is intended to confer any rights or remedies under or by reason of this Lease on any third parties other than any successors or assigns to either party hereto.

35. **No Purchase Preference.** LESSEE understands and acknowledges that it does not and shall not have a preference right to purchase the Land during the Lease term and that it does not and shall not have a right to purchase the Land upon termination or expiration of the Lease term or to receive compensation for improvements placed upon the Land during the Lease term.

36. **Time of Essence.** Time is expressly declared to be of the essence of this Lease and each and every covenant of LESSEE hereunder.

37. **Amendments.** Any amendments, revisions, supplements, or additions to this Lease or attached exhibits shall be made in writing executed by the parties hereto, and neither LESSOR nor LESSEE shall be bound by verbal or implied agreements.

38. **Entire Agreement.** This written Lease contains the entire agreement of the parties hereto with respect to the matters covered hereby, and no other agreement, statement or promise made by any party hereto, or to any employee, officer or agent of any party hereto, which is not contained or referenced herein, shall be binding or valid.

39. **Invalidity.** If any term or provision of this Lease or the application thereof to any person or circumstance shall to any extent prove to be invalid, unenforceable, void, or illegal, the remainder of this Lease shall be deemed void and terminated.

40. **Controlling Law.** This Lease shall be governed by and construed according to the laws of the State of Utah.

41. **Lease Subject to Law.** This Lease is issued pursuant to and subject to all valid federal, state, county and municipal laws and ordinances including the terms and provisions of Chapter 65A-1 et. seq. Utah Code Annotated (1953, as amended). This Lease is subject to the rules of the Division now or hereafter in force and to the orders of the Director of the Division now or hereafter in force, when not inconsistent with the express and specific provisions herein.

42. **Consent to Suit.** The LESSEE and LESSOR consent to suit in the courts of the State of Utah (State or Federal) in any dispute arising under the terms of this Lease or as a result of operations carried on under this Lease. LESSEE acknowledges that LESSEE's registered agent in the State of Utah is authorized to receive service of process for any action under this Lease.

43. **Venue.** The LESSEE agrees for itself, its heirs, successors and assigns that any suit brought by the LESSEE, its successors or assigns, concerning this Lease in any court must be maintained only in the Utah State District Court of Salt Lake County or Box Elder County or the United States District Court for the District of Utah subject to jurisdictional requirements. Provided, however, nothing in this provision shall restrict LESSEE's right or ability to administrative process from any appropriate state or federal agency.

45. **No Waiver.** Either party's waiver of any breach or failure to enforce any of the provisions of this Lease will not in any way limit or waive that party's right to enforce or compel strict compliance with every provision of this Lease, any course of dealing notwithstanding.

46. **Attorney's Fees.** In the event either party shall prevail in any action or suit for the enforcement of any provision of this Lease or concerning this Lease in any manner, the prevailing party shall be entitled to reimbursement of reasonable attorney's fees on account thereof.

47. **Elective Termination.** LESSEE may at any time terminate this Lease upon giving LESSOR ten (10) days prior notice. LESSOR may at any time terminate this Lease upon giving LESSEE ten (10) days prior notice.

48. **Recording.** LESSEE shall cause this Lease to be recorded in the office of the Box Elder County Recorder, State of Utah.

49. **Notice.** Any notice contemplated herein to be served upon LESSEE shall be in writing and shall be deemed sufficient if deposited in the United States mail, postage prepaid and certified or registered, and addressed as follows:

UNION PACIFIC RAILROAD COMPANY
Tony K. Love, Assistant Vice President-Real Estate
1400 Douglas Street, MS 1690
Omaha, Nebraska 68179

UNION PACIFIC RAILROAD COMPANY
Gayla L. Thal, Vice President-Law
1400 Douglas Street, MS 1510
Omaha, Nebraska 68179

or at any such other address as LESSEE may from time to time designate by written notice to LESSOR. Any notice to be served on LESSOR shall be in writing and shall be deemed sufficient if deposited in the United States mail, postage prepaid and certified or registered, and addressed to the address listed above the LESSOR'S signature block.

50. **Responsibilities of Successors.** The provisions hereof shall inure to and be binding upon the successors and assigns of LESSEE.

IN WITNESS WHEREOF, LESSOR and LESSEE have caused this Special Use Lease Agreement to be executed by their respective, duly authorized representatives as of the day and year first herein above written.

LESSOR: DIVISION OF FORESTRY, FIRE AND STATE LANDS
1594 West North Temple, Suite 3520
PO Box 145703
Salt Lake City, Utah 84114-5703

By: Brian L. Cottam
Brian L. Cottam, Director

STATE OF UTAH)
: ss.

COUNTY OF SALT LAKE)

On the 17 day of September, 2015, personally appeared before me, who being by me duly sworn did say that he, Brian L. Cottam, is the Director of the Division of Forestry, Fire and State Lands, and the signer of the above instrument, who duly acknowledged that he executed the same.

Given under my hand and seal this 17 day of September, 2015.

Seal:

Jamie Barnes
Notary Public

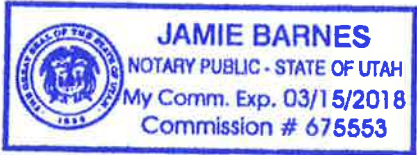

LESSEE: UNION PACIFIC RAILROAD COMPANY,
a Delaware corporation
1400 Douglas Street, MS 1690
Omaha, NE 68179

By: Cameron A. Scott
Name: Cameron A. Scott
Its: Executive Vice President - Operations

STATE OF NEBRASKA)

: ss.

COUNTY OF)

On the 11th day of September, 20 15, personally appeared before me, who
being by me duly sworn did say that he, Cameron Scott, is the Executive Vice
President - Operations of Union Pacific Railroad Company, and the signer of the above instrument,
who duly acknowledged that he executed the same.

Given under my hand and seal this 11th day of September, 20 15.

Seal:

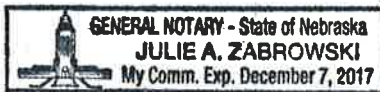

Julie A. Zabrowski
Notary Public

APPROVED AS TO FORM:
SEAN REYES
ATTORNEY GENERAL

BY: 
Fredric J. Donaldson
Assistant Attorney General

EXHIBIT A

SEGMENT 1

BEING A 400 AND 550 FOOT WIDE SPECIAL USE LEASE AGREEMENT BOUNDARY LOCATED OVER, ALONG AND ACROSS THE GREAT SALT LAKE, BOX ELDER COUNTY, STATE OF UTAH, BEING MORE PARTICULARLY DESCRIBED AS FOLLOWS:

COMMENCING AT THE SOUTHEAST CORNER OF SECTION 22, T6N, R9W, SALT LAKE BASE AND MERIDIAN, A FOUND GLO BRASS CAP, WHENCE THE SOUTHWEST CORNER OF SAID SECTION 22, A FOUND GLO BRASS CAP, BEARS N 89°04' 56" W, A DISTANCE OF 5284.84 FEET (BASIS OF BEARING), THENCE N 23°20' 18" W, A DISTANCE OF 2518.19 FEET TO THE SOUTHWESTERLY CORNER OF THIS SPECIAL USE LEASE AGREEMENT BOUNDARY AT THE INTERSECTION OF THE MEANDER LINE OF THE GREAT SALT LAKE (AS ESTABLISHED BY THE 1929 SURVEY) AND THE POINT OF BEGINNING;

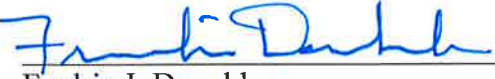
THENCE N 07°19' 16" W, CONTINUING ALONG SAID MEANDER LINE, A DISTANCE OF 207.24 FEET TO AN ANGLE POINT;

THENCE N 25°10' 44" E, CONTINUING ALONG SAID MEANDER LINE, A DISTANCE OF 212.57 FEET TO THE NORTHWESTERLY CORNER OF THIS SPECIAL USE LEASE AGREEMENT BOUNDARY;

THENCE S 87°54' 03" E, OVER AND ACROSS THE GREAT SALT LAKE, A DISTANCE OF 24679.97 FEET TO THE WESTERLY LINE OF A GRANT OF EASEMENT RECORDED IN BOOK 106, PAGE 43; (SEPTEMBER 13, 1956);

THENCE S 01°41' 31" W, CONTINUING ALONG SAID WESTERLY LINE, A DISTANCE OF 400.01 FEET;

THENCE N 87° 54' 03" W, OVER AND ACROSS THE GREAT SALT LAKE, A DISTANCE OF 611.87 FEET;

THENCE S 02° 05' 57" W, A DISTANCE OF 150.00 FEET

THENCE N 87° 54' 03" W, A DISTANCE OF 150.00 FEET

THENCE N 02° 05' 57" E, A DISTANCE OF 150.00 FEET

THENCE N 87°54' 03" W, A DISTANCE OF 23,970.36 FEET TO THE POINT OF BEGINNING

CONTAINING 227.66 ACRES (9916794 SQ. FEET), MORE OR LESS.

SEGMENT 2

BEING A 400 FOOT WIDE SPECIAL USE LEASE AGREEMENT BOUNDARY LOCATED OVER, ALONG AND ACROSS THE GREAT SALT LAKE, BOX ELDER COUNTY, STATE OF UTAH, BEING MORE PARTICULARLY DESCRIBED AS FOLLOWS:

COMMENCING AT THE SOUTHWEST CORNER OF SECTION 30, T6N, R5W, SALT LAKE BASE AND MERIDIAN, A FOUND STONE AND ½" REBAR WHENCE THE SOUTH QUARTER CORNER OF SAID SECTION 30, A FOUND BRASS CAP, BEARS S 89°29' 05" E, A DISTANCE OF 2650.17 FEET (BASIS OF BEARING), THENCE N 89°30' 58" W, A DISTANCE OF 634.28 FEET TO THE NORTHERLY LINE OF THE SOUTHERN PACIFIC RAILROAD RIGHT OF WAY (UNION PACIFIC RAILROAD), SAME BEING THE SOUTHERLY LINE OF THAT CERTAIN 128.96 ACRE TRACT AS SHOWN AND DESCRIBED IN FILE NO. 88061-FF45, BOX ELDER COUNTY, UTAH;

THENCE N 68°09' 44" W, CONTINUING ALONG SAID NORTHERLY RIGHT OF WAY LINE OF SOUTHERN PACIFIC RAILROAD (UNION PACIFIC RAILROAD) AND SAID SOUTHERLY LINE OF THAT CERTAIN 128.96 ACRE TRACT, A DISTANCE OF 3377.58 FEET TO AN INTERIOR CORNER OF SAID CERTAIN 128.96 ACRE TRACT, THENCE S 52°43' 53" E, A DISTANCE OF 39.24 FEET TO THE NORTHEASTERLY CORNER OF THIS SPECIAL USE LEASE AGREEMENT BOUNDARY AND THE POINT OF BEGINNING;

THENCE S 52°43' 53" E, ALONG THE MEANDER LINE OF THE GREAT SALT LAKE (1886 SURVEY) AT 700.89 FEET PASS THE CURRENT CENTERLINE OF TRACK NO. 1 (UNION PACIFIC RAILROAD) IN ALL A DISTANCE OF 1465.53 FEET;

THENCE N 68°08' 50" W, TANGENT TO THE FOLLOWING DESCRIBED CURVE AND OVER AND ACROSS THE GREAT SALT LAKE, A DISTANCE OF 1079.35 FEET;

THENCE 1696.83 FEET, ALONG THE ARC OF SAID TANGENT CURVE TO THE LEFT HAVING A RADIUS OF 4934.95 FEET, A CENTRAL ANGLE OF 19°42' 02", AND A CHORD WHICH BEARS N 77°59' 51" W, A DISTANCE OF 1688.49 FEET;

THENCE N 87°50' 51" W, A DISTANCE OF 10515.95 FEET TO THE EASTERLY LINE OF A GRANT OF EASEMENT RECORDED IN BOOK 106, PAGE 43; (SEPTEMBER 13, 1956);

THENCE N 03°53' 42" E, CONTINUING ALONG SAID EASTERLY LINE, A DISTANCE OF 400.19 FEET;

THENCE S 87°50' 51" E, DEPARTING SAID EASTERLY LINE AND OVER AND ACROSS THE GREAT SALT LAKE AND TANGENT TO THE FOLLOWING DESCRIBED CURVE, A DISTANCE OF 10503.78 FEET;

THENCE 1500.70 FEET, ALONG THE ARC OF SAID TANGENT CURVE TO THE RIGHT HAVING A RADIUS OF 5334.95 FEET, A CENTRAL ANGLE OF 16°07' 01", AND A CHORD WHICH BEARS S 79°47' 21" E, A DISTANCE OF 1495.75 FEET TO THE POINT OF BEGINNING.

CONTAINING 116.005 ACRES (5,053,163 SQ. FEET), MORE OR LESS.

SEGMENT 3

A 400.00 FOOT WIDE SPECIAL USE LEASE AGREEMENT BOUNDARY LOCATED OVER, ALONG AND ACROSS THE GREAT SALT LAKE BEING SITUATED IN BOX ELDER COUNTY UTAH MORE PARTICULARLY DESCRIBED AS FOLLOWS:

BEGINNING AT A POINT ON GREAT SALT LAKE MEANDER LINE LOCATED 347.76 FEET S89°59'24"E TO THE GREAT SALT LAKE MEANDER CORNER OF SECTION 28 AND 33, T 6N, R 5W OF THE SALT LAKE BASE AND MERIDIAN MONUMENTED WITH A MARKED STONE AND 237.67 FEET S08°25'13"E FROM THE SOUTHWEST CORNER OF SAID SECTION 28 BEING A BOX ELDER COUNTY ALUMINUM CAP MONUMENT;

RUNNING THENCE ALONG SAID MEANDER LINE OF SAID SECTION 33 FOLLOWING TWO (2) COURSES; (1) S08°25'13"E 381.30 FEET; AND (2) S19°10'11"E 144.26 FEET TO THE SOUTHEASTERLY RIGHT-OF-WAY LINE OF SAID 400.00 FOOT WIDE SPECIAL USE LEASE AGREEMENT BOUNDARY; THENCE ALONG SAID SOUTHEASTERLY RIGHT-OF-WAY LINE THE FOLLOWING THREE (3) COURSES; (1) IN A NORTHEASTERLY DIRECTION TO THE LEFT OF A NON-TANGENT 3882.80 FOOT RADIUS CURVE, A DISTANCE OF 217.89 FEET, CHORD BEARS N39°00'52"E 217.87 FEET, HAVING A CENTRAL ANGLE OF 03°12'55"; (2) N37°24'25"E 2955.75 FEET; AND (3) TO THE RIGHT ALONG THE ARC OF A 4300.00 FOOT RADIUS CURVE, A DISTANCE OF 1226.78 FEET, CHORD BEARS N45°34'48"E 1222.62 FEET, HAVING A CENTRAL ANGLE OF 16°20'47" TO THE MEANDER LINE OF THE GREAT SALT LAKE; THENCE ALONG SAID MEANDER LINE OF SAID SECTION 28 THE FOLLOWING THREE (3) COURSES; (1) S76°15'00"W 288.31 FEET; (2) S52°15'00"W 396.00 FEET; AND (3) S72°45'00"W 496.81 FEET TO THE NORTHWESTERLY RIGHT-OF-WAY LINE OF SAID 400.00 FOOT WIDE SPECIAL USE LEASE AGREEMENT BOUNDARY; THENCE ALONG SAID NORTHWESTERLY RIGHT-OF-WAY LINE THE FOLLOWING TWO (2) COURSES; (1) IN A SOUTHWESTERLY DIRECTION TO THE LEFT OF A NON-TANGENT 4700.00 FOOT RADIUS CURVE, A DISTANCE OF 197.67 FEET, CHORD BEARS S38°36'42"W 197.66 FEET HAVING A CENTRAL ANGLE OF 02°24'35"; AND (2) S37°24'25"W 2828.37 FEET TO THE POINT OF BEGINNING.

CONTAINING 33.30 ACRES MORE OR LESS.

SEGMENT 4

A 400 FOOT WIDE SPECIAL USE LEASE AGREEMENT BOUNDARY LOCATED OVER, ALONG AND ACROSS THE OGDEN BAY OF THE GREAT SALT LAKE BEING SITUATED IN WEBER COUNTY AND BOX ELDER COUNTY UTAH MORE PARTICULARLY DESCRIBED AS FOLLOWS:

BEGINNING AT THE GREAT SALT LAKE MEANDER CORNER OF SECTIONS 19 AND 24, T 6N, R 3W AND 4W OF THE SALT LAKE BASE AND MERIDIAN MONUMENTED WITH A BRASS CAP SET BY THE B.L.M. IN 1968, SAID MONUMENT BEING LOCATED 2412.96 FEET S00°26'10"W FROM THE NORTHEAST CORNER OF SAID SECTION 24 BEING A WEBER COUNTY BRASS CAP MONUMENT;

RUNNING THENCE ALONG THE GREAT SALT LAKE MEANDER LINE ALONG SAID SECTION 24 THE FOLLOWING TWO (2) COURSES: (1) N89°02'32"W 1980.00 FEET; AND (2) N75°02'32"W 1547.04 FEET TO THE NORTHERLY RIGHT-OF-WAY LINE OF SAID 400.00 FOOT WIDE SPECIAL USE LEASE AGREEMENT BOUNDARY; THENCE ALONG SAID NORTHERLY RIGHT-OF-WAY LINE THE FOLLOWING THREE (3) COURSES; (1) N83°46'50"W 2253.63 FEET; (2) TO THE LEFT ALONG THE ARC OF A 12450.00 FOOT RADIUS CURVE A DISTANCE OF 3793.50 FEET, CHORD BEARS S87°29'26"W 3778.84 FEET, HAVING A CENTRAL ANGLE OF 17°27'29"; AND (3) S78°45'41"W 38250.64 FEET TO THE MEANDER LINE OF GREAT SALT LAKE, BEING A POINT LOCATED S01°13'07"W 1468.79 FEET FROM THE NORTHEAST CORNER OF SECTION 28, T 6N, R 5W OF THE SALT LAKE BASE AND MERIDIAN BEING A MARKED STONE; THENCE ALONG SAID GREAT SALT LAKE MEANDER LINE ALONG SECTION 28, T 6N, R 5W OF THE SALT LAKE BASE AND MERIDIAN THE FOLLOWING FIVE (5) COURSES; (1) S37°45'00"W 97.75 FEET; (2) S39°25'00"W 264.00 FEET; (3) S83°00'00"W 297.00 FEET; (4) S43°30'00"W 297.00 FEET; AND (5) S66°15'00"W 298.45 FEET TO THE SOUTHERLY RIGHT-OF-WAY LINE OF SAID 400.00 FOOT WIDE SPECIAL USE LEASE AGREEMENT BOUNDARY; THENCE ALONG SAID SOUTHERLY RIGHT-OF-WAY LINE THE FOLLOWING FIVE (5) COURSES: (1) IN A EASTERLY DIRECTION TO THE RIGHT OF A NON TANGENT 4300.00 FOOT RADIUS CURVE, A DISTANCE OF 627.34 FEET, CHORD BEARS N74°34'55"E 626.79 FEET, HAVING A CENTRAL ANGLE OF 08°21'33"; (2) N78°45'41"E 38733.50 FEET; (3) TO THE RIGHT ALONG THE ARC OF A 12050.00 FOOT RADIUS CURVE, A DISTANCE OF 3671.62 FEET, CHORD BEARS N87°29'26"E 3657.43 FEET, HAVING A CENTRAL ANGLE OF 17°27'29"; (4) S83°46'50"E 5307.85 FEET; AND (5) TO THE LEFT ALONG THE ARC OF A 10197.50 FOOT RADIUS CURVE, A DISTANCE OF 1671.43 FEET, CHORD BEARS S88°28'34"E 1669.56 FEET, HAVING A CENTRAL ANGLE OF 09°23'28" TO THE MEANDER LINE OF THE GREAT SALT LAKE ALONG SECTION 19, T 6N, R 3W OF THE SALT LAKE BASE AND MERIDIAN; THENCE ALONG SAID MEANDER LINE N74°00'00"W 1235.39 FEET TO THE POINT OF BEGINNING.

CONTAINING 436.46 ACRES MORE OR LESS.

APPENDIX G

UPPR-UDWQ-USACE MOU and UDWQ-UDFFSL MOU
(XXXX, 2017)

[To be added when completed]

